

CRT Video Timer and Controller VTAC®

FEATURES

- Fully Programmable Display Format
 - Characters per data row (1-200)
 - Data rows per frame (1-64)
 - Raster scans per data row (1-16)
- Programmable Monitor Sync Format
 - Raster Scans/Frame (256-1023)
 - "Front Porch"
 - Sync Width
 - "Back Porch"
 - Interlace/Non-Interlace
 - Vertical Blanking
- Lock Line Input (CRT 5057)
- Direct Outputs to CRT Monitor
 - Horizontal Sync
 - Vertical Sync
 - Composite Sync (CRT 5027, CRT 5037)
 - Blanking
 - Cursor coincidence
- Programmed via:
 - Processor data bus
 - External PROM
 - Mask Option ROM
- Standard or Non-Standard CRT Monitor Compatible
- Refresh Rate: 60Hz, 50Hz, ...
- Scrolling
 - Single Line
 - Multi-Line
- Cursor Position Registers
- Character Format: 5x7, 7x9, ...
- Programmable Vertical Data Positioning
- Balanced Beam Current Interlace (CRT 5037)
- Graphics Compatible

PIN CONFIGURATION

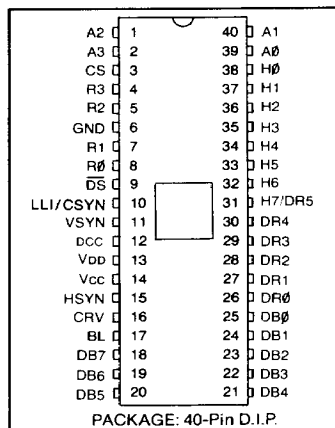

PACKAGE: 40-Pin D.I.P.

- Split-Screen Applications
 - Horizontal
 - Vertical
- Interlace or Non-Interlace operation
- TTL Compatibility
- BUS Oriented
- High Speed Operation
- COPLAMOS® N-Channel Silicon Gate Technology
- Compatible with CRT 8002 VDAC™
- Compatible with CRT 7004

GENERAL DESCRIPTION

The CRT Video Timer and Controller Chip (VTAC)® is a user programmable 40-pin COPLAMOS® n channel MOS/LSI device containing the logic functions required to generate all the timing signals for the presentation and formatting of interlaced and non-interlaced video data on a standard or non-standard CRT monitor.

With the exception of the dot counter, which may be clocked at a video frequency above 25 MHz and therefore not recommended for MOS implementation, all frame formatting, such as horizontal, vertical, and composite sync, characters per data row, data rows per frame, and raster scans per data row and per frame are totally user programmable. The data row counter has been designed to facilitate scrolling.

Programming is effected by loading seven 8 bit control registers directly off an 8 bit bidirectional data bus. Four register address lines and a chip select line provide complete microprocessor compatibility for program controlled set up. The device can be "self loaded" via an external PROM tied on the data bus as described in the OPERATION section. Formatting can also be programmed by a single mask option.

In addition to the seven control registers two additional registers are provided to store the cursor character and data row addresses for generation of the cursor video signal. The contents of these two registers can also be read out onto the bus for update by the program.

Three versions of the VTAC® are available. The CRT 5027 provides non-interlaced operation with an even or odd number of scan lines per data row, or interlaced operation with an even number of scan lines per data row. The CRT 5037 may be programmed for an odd or even number of scan lines per data row in both interlaced and non-interlaced modes. Programming the CRT 5037 for an odd number of scan lines per data row eliminates character distortion caused by the uneven beam current normally associated with odd field/even field interlacing of alphanumeric displays.

The CRT 5057 provides the ability to lock a CRT's vertical refresh rate, as controlled by the VTAC's® vertical sync pulse, to the 50 Hz or 60 Hz line frequency thereby eliminating the so called "swim" phenomenon. This is particularly well suited for European system requirements. The line frequency waveform, processed to conform to the VTAC's® specified logic levels, is applied to the line lock input. The VTAC® will inhibit generation of vertical sync until a zero to one transition on this input is detected. The vertical sync pulse is then initiated within one scan line after this transition rises above the logic threshold of the VTAC.®

To provide the pin required for the line lock input, the composite sync output is not provided in the CRT 5057.

Description of Pin Functions

Pin No.	Symbol	Name	Input/ Output	Function
25-18	DB $\bar{0}$ -7	Data Bus	I/O	Data bus. Input bus for control words from microprocessor or PROM. Bidirectional bus for cursor address.
3	CS	Chip Select	I	Signals chip that it is being addressed
39, 40, 1, 2	A $\bar{0}$ -3	Register Address	I	Register address bits for selecting one of seven control registers or either of the cursor address registers
9	$\bar{D}S$	Data Strobe	I	Strobes DB $\bar{0}$ -7 into the appropriate register or outputs the cursor character address or cursor line address onto the data bus
12	DCC	DOT Counter Carry	I	Carry from off chip dot counter establishing basic character clock rate. Character clock.
38-32	H $\bar{0}$ -6	Character Counter Outputs	O	Character counter outputs.
7, 5, 4	R1-3	Scan Counter Outputs	O	Three most significant bits of the Scan Counter; row select inputs to character generator.
31	H7/DR5	H7/DR5	O	Pin definition is user programmable. Output is MSB of Character Counter if horizontal line count (REG. $\bar{0}$) is ≥ 128 ; otherwise output is MSB of Data Row Counter.
8	R $\bar{0}$	Scan Counter LSB	O	Least significant bit of the scan counter. In the interlaced mode with an even number of scans per data row, R $\bar{0}$ will toggle at the field rate; for an odd number of scans per data row in the interlaced mode, R $\bar{0}$ will toggle at the data row rate.
26-30	DR $\bar{0}$ -4	Data Row Counter Outputs	O	Data Row counter outputs.
17	BL	Blank	O	Defines non active portion of horizontal and vertical scans.
15	HSYN	Horizontal Sync	O	Initiates horizontal retrace.
11	VSYN	Vertical Sync	O	Initiates vertical retrace.
10	CSYN/ LLI	Composite Sync Output/ Line Lock Input	O/I	Composite sync is provided on the CRT 5027 and CRT 5037. This output is active in non-interlaced mode only. Provides a true RS-170 composite sync wave form. For the CRT 5057, this pin is the Line Lock Input. The line frequency waveform, processed to conform to the VTAC's [®] specified logic levels, is applied to this pin.
16	CRV	Cursor Video	O	Defines cursor location in data field.
14	V _{CC}	Power Supply	PS	+5 volt Power Supply
13	V _{DD}	Power Supply	PS	+12 volt Power Supply

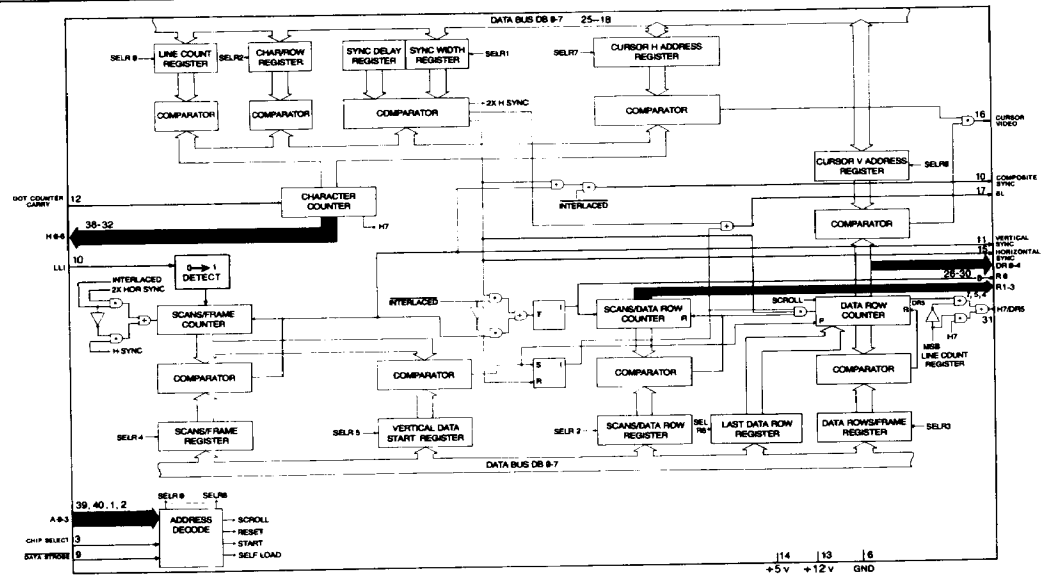

Operation

The design philosophy employed was to allow the device to interface effectively with either a microprocessor based or hardware logic system. The device is programmed by the user in one of two ways; via the processor data bus as part of the system initialization routine, or during power up via a PROM tied on the data bus and addressed directly by the Row Select outputs of the chip. (See figure 4). Seven 8 bit words are required to fully program the chip. Bit assignments for these words are shown in Table 1. The information contained in these seven words consists of the following:

Horizontal Formatting:	
Characters/Data Row	A 3 bit code providing 8 mask programmable character lengths from 20 to 132. The standard device will be masked for the following character lengths; 20, 32, 40, 64, 72, 80, 96, and 132.
Horizontal Sync Delay	3 bits assigned providing up to 8 character times for generation of "front porch".
Horizontal Sync Width	4 bits assigned providing up to 15 character times for generation of horizontal sync width.
Horizontal Line Count	8 bits assigned providing up to 256 character times for total horizontal formatting.
Skew Bits	A 2 bit code providing from a 0 to 2 character skew (delay) between the horizontal address counter and the blank and sync (horizontal, vertical, composite) signals to allow for retiming of video data prior to generation of composite video signal. The Cursor Video signal is also skewed as a function of this code.
Vertical Formatting:	
Interlaced/Non-interlaced	This bit provides for data presentation with odd/even field formatting for interlaced systems. It modifies the vertical timing counters as described below. A logic 1 establishes the interlace mode.
Scans/Frame	8 bits assigned, defined according to the following equations: Let X = value of 8 assigned bits. 1) in interlaced mode—scans/frame = $2X + 513$. Therefore for 525 scans, program X = 6 (00000110). Vertical sync will occur precisely every 262.5 scans, thereby producing two interlaced fields. Range = 513 to 1023 scans/frame, odd counts only. 2) in non-interlaced mode—scans/frame = $2X + 256$. Therefore for 262 scans, program X = 3 (00000011). Range = 256 to 766 scans/frame, even counts only. In either mode, vertical sync width is fixed at three horizontal scans (= 3H).
Vertical Data Start	8 bits defining the number of raster scans from the leading edge of vertical sync until the start of display data. At this raster scan the data row counter is set to the data row address at the top of the page.
Data Rows/Frame	6 bits assigned providing up to 64 data rows per frame.
Last Data Row	6 bits to allow up or down scrolling via a preload defining the count of the last displayed data row.
Scans/Data Row	4 bits assigned providing up to 16 scan lines per data row.

Additional Features

Device Initialization:

Under microprocessor control—The device can be reset under system or program control by presenting a 1010 address on A3- \emptyset . The device will remain reset at the top of the even field page until a start command is executed by presenting a 1110 address on A3- \emptyset .

Via "Self Loading"—In a non-processor environment, the self loading sequence is effected by presenting and holding the 1111 address on A3- \emptyset , and is initiated by the receipt of the strobe pulse (DS). The 1111 address should be maintained long enough to insure that all seven registers have been loaded (in most applications under one millisecond). The timing sequence will begin one line scan after the 1111 address is removed. In processor based systems, self loading is initiated by presenting the $\emptyset 111$ address to the device. Self loading is terminated by presenting the start command to the device which also initiates the timing chain.

Scrolling—In addition to the Register 6 storage of the last displayed data row a "scroll" command (address 1011) presented to the device will increment the first displayed data row count to facilitate up scrolling in certain applications.

Control Registers Programming Chart

Horizontal Line Count: Characters/Data Row:	Total Characters/Line = $N + 1$, $N = 0$ to 255 (DB0 = LSB) <table border="0" style="margin-left: 20px;"> <tr><td>DB2</td><td>DB1</td><td>DB0</td><td></td></tr> <tr><td>0</td><td>0</td><td>0</td><td>= 20 Active Characters/Data Row</td></tr> <tr><td>0</td><td>0</td><td>1</td><td>= 32</td></tr> <tr><td>0</td><td>1</td><td>0</td><td>= 40</td></tr> <tr><td>0</td><td>1</td><td>1</td><td>= 64</td></tr> <tr><td>1</td><td>0</td><td>0</td><td>= 72</td></tr> <tr><td>1</td><td>0</td><td>1</td><td>= 80</td></tr> <tr><td>1</td><td>1</td><td>0</td><td>= 96</td></tr> <tr><td>1</td><td>1</td><td>1</td><td>= 132</td></tr> </table>	DB2	DB1	DB0		0	0	0	= 20 Active Characters/Data Row	0	0	1	= 32	0	1	0	= 40	0	1	1	= 64	1	0	0	= 72	1	0	1	= 80	1	1	0	= 96	1	1	1	= 132
DB2	DB1	DB0																																			
0	0	0	= 20 Active Characters/Data Row																																		
0	0	1	= 32																																		
0	1	0	= 40																																		
0	1	1	= 64																																		
1	0	0	= 72																																		
1	0	1	= 80																																		
1	1	0	= 96																																		
1	1	1	= 132																																		
Horizontal Sync Delay: Horizontal Sync Width:	= N , from 1 to 7 character times (DB0 = LSB) ($N = 0$ Disallowed) = N , from 1 to 15 character times (DB3 = LSB) ($N = 0$ Disallowed) <div style="text-align: center;"> Sync/Blank Delay Cursor Delay (Character Times) </div>																																				
Skew Bits	<table border="0" style="margin-left: 20px;"> <tr><td>DB7</td><td>DB6</td><td></td><td></td></tr> <tr><td>0</td><td>0</td><td>0</td><td>0</td></tr> <tr><td>1</td><td>0</td><td>1</td><td>0</td></tr> <tr><td>0</td><td>1</td><td>2</td><td>1</td></tr> <tr><td>1</td><td>1</td><td>2</td><td>2</td></tr> </table>	DB7	DB6			0	0	0	0	1	0	1	0	0	1	2	1	1	1	2	2																
DB7	DB6																																				
0	0	0	0																																		
1	0	1	0																																		
0	1	2	1																																		
1	1	2	2																																		
Scans/Frame	8 bits assigned, defined according to the following equations: Let X = value of 8 assigned bits. (DB0 = LSB) 1) in interlaced mode—scans/frame = $2X + 513$. Therefore for 525 scans, program $X = 6$ (00000110). Vertical sync will occur precisely every 262.5 scans, thereby producing two interlaced fields. Range = 513 to 1023 scans/frame, odd counts only. 2) in non-interlaced mode—scans/frame = $2X + 256$. Therefore for 262 scans, program $X = 3$ (00000011). Range = 256 to 766 scans/frame, even counts only. In either mode, vertical sync width is fixed at three horizontal scans (= 3H). N = number of raster lines delay after leading edge of vertical sync of vertical start position. (DB0 = LSB)																																				
Vertical Data Start:	N = number of raster lines delay after leading edge of vertical sync of vertical start position. (DB0 = LSB)																																				
Data Rows/Frame: Last Data Row:	Number of data rows = $N + 1$, $N = 0$ to 63 (DB0 = LSB) N = Address of last displayed data row, $N = 0$ to 63, ie; for 24 data rows, program $N = 23$. (DB0 = LSB)																																				
Mode: Scans/Data Row:	Register, 1, DB7 = 1 establishes Interlace. <div style="text-align: center;">Interlace Mode</div> CRT 5027: Scans per Data Row = $N + 1$ where N = programmed number of scans/data rows. $N = 0$ to 15. Scans per data row must be even counts only. CRT 5037, CRT 5057: Scans per data Row = $N + 2$. $N = 0$ to 14, odd or even counts. <div style="text-align: center;">Non-Interlace Mode</div> CRT 5027, CRT 5037, CRT 5057: Scans per Data Row = $N + 1$, odd or even count. $N = 0$ to 15.																																				

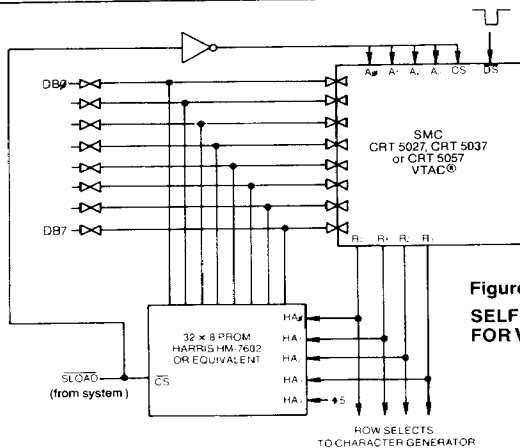

Figure 4.
SELF LOADING SCHEME
FOR VTAC® SET-UP

Register Selects/Command Codes

A3	A2	A1	A0	Select/Command	Description
0	0	0	0	Load Control Register 0	See Table 1
0	0	0	1	Load Control Register 1	
0	0	1	0	Load Control Register 2	
0	0	1	1	Load Control Register 3	
0	1	0	0	Load Control Register 4	
0	1	0	1	Load Control Register 5	
0	1	1	0	Load Control Register 6	
0	1	1	1	Processor Initiated Self Load	
1	0	0	0	Read Cursor Line Address	Resets timing chain to top left of page. Reset is latched on chip by DS and counters are held until released by start command.
1	0	0	1	Read Cursor Character Address	
1	0	1	0	Reset	
1	0	1	1	Up Scroll	Increments address of first displayed data row on page, ie; prior to receipt of scroll command—top line = 0, bottom line = 23. After receipt of Scroll Command—top line = 1, bottom line = 0.
1	1	0	0	Load Cursor Character Address*	Receipt of this command after a Reset or Processor Self Load command will release the timing chain approximately one scan line later. In applications requiring synchronous operation of more than one CRT 5027 the dot counter carry should be held low during the DS for this command.
1	1	0	1	Load Cursor Line Address*	
1	1	1	0	Start Timing Chain	
1	1	1	1	Non-Processor Self Load	Device will begin self load via PROM when DS goes low. The 1111 command should be maintained on A3-0 long enough to guarantee self load. (Scan counter should cycle through at least once). Self load is automatically terminated and timing chain initiated when the all "1's" condition is removed, independent of DS. For synchronous operation of more than one VTAC [®] , the Dot Counter Carry should be held low when the command is removed.

SECTION V

*NOTE: During Self-Load, the Cursor Character Address Register (REG 7) and the Cursor Row Address Register (REG 8) are enabled during states 0111 and 1000 of the R3-R0 Scan Counter outputs respectively. Therefore, Cursor data in the PROM should be stored at these addresses.

TABLE 1

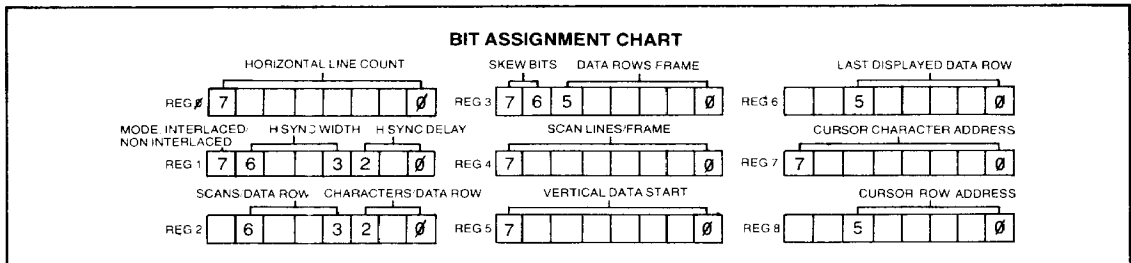

AC TIMING DIAGRAMS

FIGURE 1 VIDEO TIMING

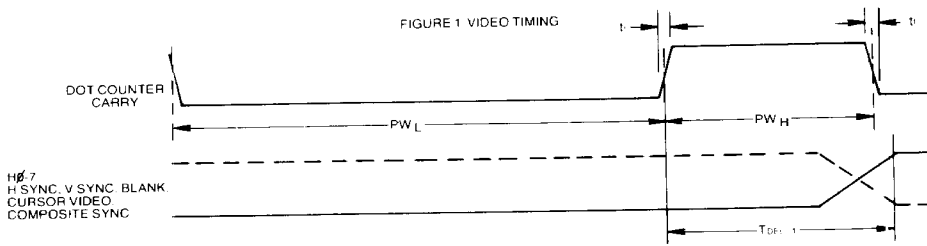

FIGURE 2 LOAD READ TIMING

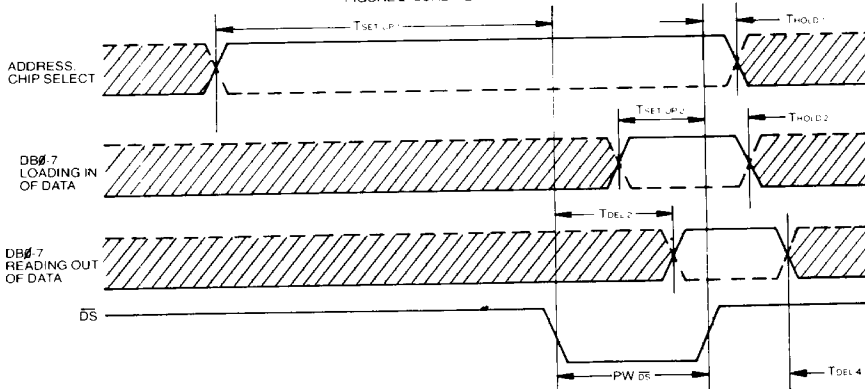
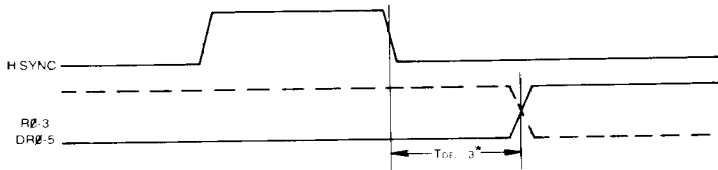
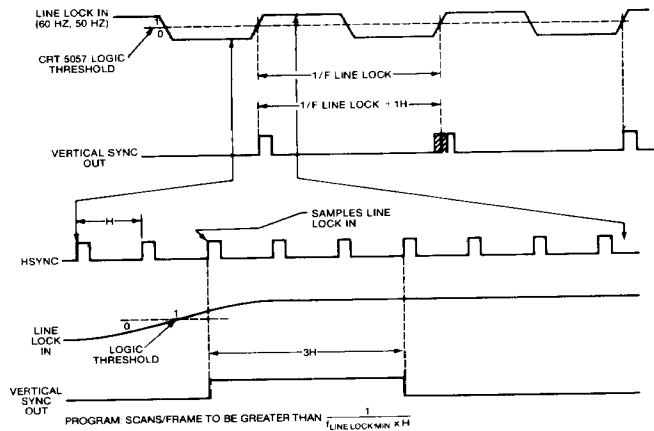

FIGURE 3 SCAN AND DATA ROW COUNTER TIMING



*R0-3 and DR0-5 may change prior to the falling edge of H sync

CRT 5057 LINE LOCK



Note: To ensure a stable display when using the line lock mode, the CRT 5057 should be used with DC coupled monitors only.

MAXIMUM GUARANTEED RATINGS*

Operating Temperature Range	0°C to + 70°C
Storage Temperature Range	- 55°C to + 150°C
Lead Temperature (soldering, 10 sec.)	+ 325°C
Positive Voltage on any Pin, with respect to ground	+ 18.0V
Negative Voltage on any Pin, with respect to ground	- 0.3V

*Stresses above those listed may cause permanent damage to the device. This is a stress rating only and functional operation of the device at these or at any other condition above those indicated in the operational sections of this specification is not implied.

NOTE: When powering this device from laboratory or system power supplies, it is important that the Absolute Maximum Ratings not be exceeded or device failure can result. Some power supplies exhibit voltage spikes or "glitches" on their outputs when the AC power is switched on and off. In addition, voltage transients on the AC power line may appear on the DC output. For example, the bench power supply programmed to deliver + 12 volts may have large voltage transients when the AC power is switched on and off. If this possibility exists it is suggested that a clamp circuit be used.

ELECTRICAL CHARACTERISTICS (TA=0°C to 70°C, VCC= + 5V±5%, VDD= - 12V±5%, unless otherwise noted)

Parameter	Min.	Typ.	Max.	Unit	Comments
D.C. CHARACTERISTICS					
INPUT VOLTAGE LEVELS					
Low Level, V _{IL}			0.8	V	
High Level, V _{IH}	V _{CC} - 1.5		V _{CC}	V	
OUTPUT VOLTAGE LEVELS					
Low Level—V _{OL} for R ₀ -3			0.4	V	I _{OL} = 3.2ma
Low Level—V _{OL} all others			0.4	V	I _{OL} = 1.6ma
High Level—V _{OH} for R ₀ -3, DB ₀ -7	2.4				I _{OH} = 80µa
High Level—V _{OH} all others	2.4				I _{OH} = 40µa
INPUT CURRENT					
Low Level, I _{IL} (Address, CS only)			250	µA	V _{IN} = 0.4V
Leakage, I _{IL} (All inputs except Address, CS)			10	µA	0 ≤ V _{IN} ≤ V _{CC}
INPUT CAPACITANCE					
Data Bus, C _{IN}		10	15	pF	
DS, Clock, C _{IN}		25	40	pF	
All other, C _{IN}		10	15	pF	
DATA BUS LEAKAGE in INPUT MODE					
I _{DB}			10	µA	0.4V ≤ V _{IN} ≤ 5.25V
POWER SUPPLY CURRENT					
I _{CC}		80	100	mA	
I _{DD}		40	70	mA	
A.C. CHARACTERISTICS					
DOT COUNTER CARRY					
frequency	0.5		4.0	MHz	Figure 1
PW _H	35			ns	Figure 1
PW _L	215			ns	Figure 1
t _r , t _f		10	50	ns	Figure 1
DATA STROBE					
PW _{DS}	150ns		10µs		Figure 2
ADDRESS, CHIP SELECT					
Set-up time	125			ns	Figure 2
Hold time	50			ns	Figure 2
DATA BUS—LOADING					
Set-up time	125			ns	Figure 2
Hold time	75			ns	Figure 2
DATA BUS—READING					
T _{DEL2}			125	ns	Figure 2, CL = 50pF
T _{DEL4}	5		60	ns	Figure 2, CL = 50pF
OUTPUTS: H ₀ -7, HS, VS, BL, CRV.					
CS-T _{DEL1}			125	ns	Figure 1, CL = 20pF
OUTPUTS: R ₀ -3, DR ₀ -5					
T _{DEL3}	*		750	ns	Figure 3, CL = 20pF

*R₀-3 and DR₀-5 may change prior to the falling edge of H sync

Restrictions

1. Only one pin is available for strobing data into the device via the data bus. The cursor X and Y coordinates are therefore loaded into the chip by presenting one set of addresses and outputted by presenting a different set of addresses. Therefore the standard WRITE and READ control signals from most microprocessors must be "NORed" externally to present a single strobe (DS) signal to the device.
2. In interlaced mode the total number of character slots assigned to the horizontal scan must be even to insure that vertical sync occurs precisely between horizontal sync pulses.

General Timing

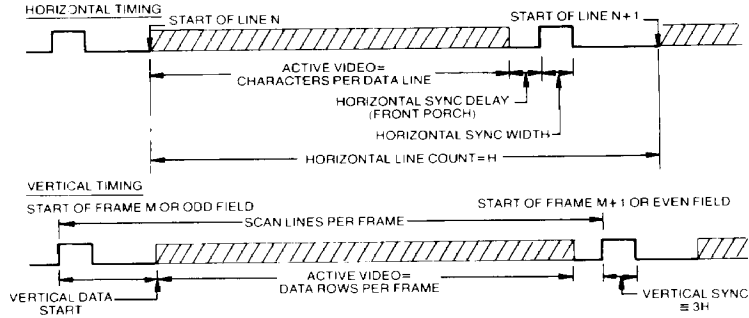

Composite Sync Timing

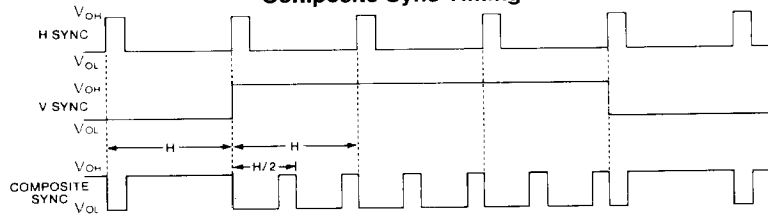

Vertical Sync Timing

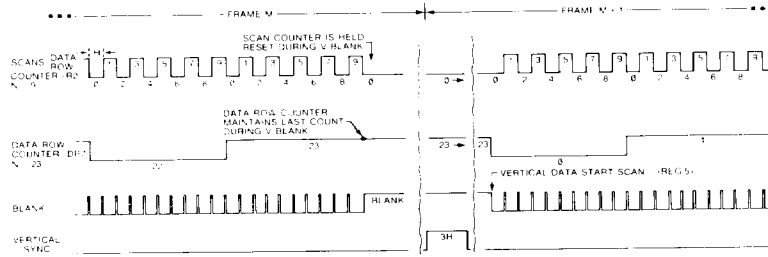

Start-up, CRT 5027

When employing microprocessor controlled loading of the CRT 5027's registers, the following sequence of instructions is necessary:

ADDRESS	COMMAND
1 1 1 0	Start Timing Chain
1 0 1 0	Reset
0 0 0 0	Load Register 0
⋮	⋮
0 1 1 0	Load Register 6
1 1 1 0	Start Timing Chain

The sequence of START RESET LOAD START is necessary to insure proper initialization of the registers.

This sequence is not required if register loading is via either of the Self Load modes. This sequence is optional with the CRT 5037 or CRT 5057.

STANDARD MICROSYSTEMS CORPORATION

35 Merritt Street, Hicksville, NY 11758
 (516) 273-3100 FAX: 516 277-8898

Circuit diagrams utilizing SMC products are included as a means of illustrating typical semiconductor applications; consequently complete information sufficient for construction purposes is not necessarily given. The information has been carefully checked and is believed to be entirely reliable. However, no responsibility is assumed for inaccuracies. Furthermore, such information does not convey to the purchaser of the semiconductor devices described any license under the patent rights of SMC or others. SMC reserves the right to make changes at any time in order to improve design and supply the best product possible.