



HM-6508

1024 x 1 CMOS RAM

Features

- Low Standby Power 50µW Max.
- Low Operating Power 20mW/MHz Max.
- Fast Access Time 180ns Max.
- Data Retention Voltage 2.0V Min.
- TTL Compatible In/Out
- High Output Drive - 2 TTL Loads
- High Noise Immunity
- On Chip Address Register
- Wide Operating Temperature Ranges:
 - ▶ HM-6508-5 0°C to +70°C
 - ▶ HM-6508-9 -40°C to +85°C
 - ▶ HM-6508-8 -55°C to +125°C

Description

The HM-6508 is a 1024 by 1 static CMOS RAM fabricated using self-aligned silicon gate technology. Synchronous circuit design techniques are employed to achieve high performance and low power operation.

On chip latches are provided for address allowing efficient interfacing with microprocessor systems. The data output buffers can be forced to a high impedance state for use in expanded memory arrays.

The HM-6508 is a fully static RAM and may be maintained in any state for an indefinite period of time. Data retention supply voltage and supply current are guaranteed over temperature.

Pinout TOP VIEW

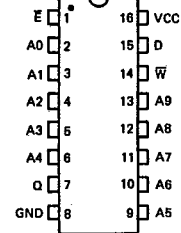

A-Address Input D-Data Input
 E-Chip Enable Q-Data Output
 W-Write Enable

Logic Symbol

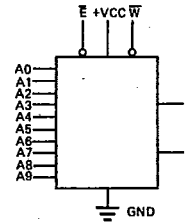

Functional Diagram

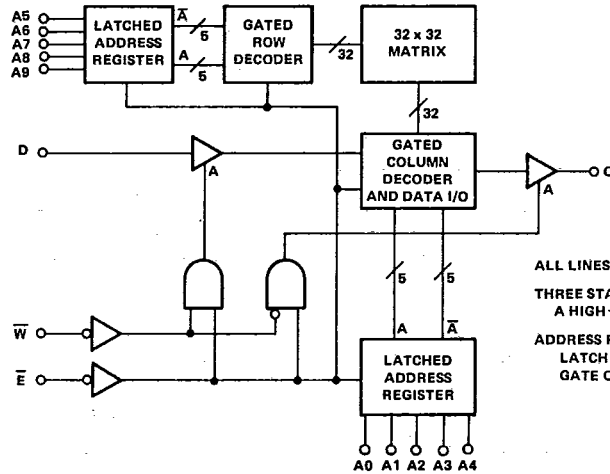

ALL LINES POSITIVE LOGIC - ACTIVE HIGH
 THREE STATE BUFFERS:
 A HIGH → OUTPUT ACTIVE
 ADDRESS REGISTER AND DECODERS:
 LATCH ON FALLING EDGE OF \bar{E}
 GATE ON FALLING EDGE OF \bar{E}

CAUTION: Electronic devices are sensitive to electrostatic discharge. Proper I.C. handling procedures should be followed.

Specifications HM-6508B-8/HM-6508B-9

HM-6508

Absolute Maximum Ratings

Supply Voltage	+7.0V
Input, Output or I/O Voltage Applied	GND -0.3V to VCC +0.3V
Storage Temperature Range	-65°C to +150°C
Maximum Package Power Dissipation	1 Watt
θ_{jc}	15°C/W (CERDIP Package)
θ_{ja}	75°C/W (CERDIP Package)
Gate Count	1925 Gates
Junction Temperature	+150°C
Lead Temperature (Soldering, Ten Seconds)	+275°C

CAUTION: Stresses above those listed in the "Absolute Maximum Ratings" may cause permanent damage to the device. This is a stress only rating and operation of the device at these or any other conditions above those indicated in the operation section of this specification is not implied.

Operating Conditions

Operating Voltage Range	+4.5V to +5.5V
Operating Temperature Ranges:	
HM-6508B-9	-40°C to +85°C
HM-6508B-8	-55°C to +125°C

D.C. Electrical Specifications VCC = 5V ± 10%; TA = HM-6508B-9 -40°C to +85°C
 TA = HM-6508B-8 -55°C to +125°C

SYMBOL	PARAMETER	MIN	MAX	UNITS	TEST CONDITIONS
ICCSB	Standby Supply Current	-	10	µA	IO = 0, VI = VCC or GND
ICCOP	Operating Supply Current (Note 3)	-	4	mA	\bar{E} = 1MHz, IO = 0, VI = VCC or GND
ICCDR	Data Retention Supply Current	-	5	µA	VCC = 2.0, IO = 0, VI = VCC or GND \bar{E} = VCC
VCCDR	Data Retention Supply Voltage	2.0	-	V	
II	Input Leakage Current	-1.0	+1.0	µA	VI = VCC or GND
IOZ	Output Leakage Current	-1.0	+1.0	µA	VO = VCC or GND
VIL	Input Low Voltage	-0.3	0.8	V	
VIH	Input High Voltage	VCC-2.0	VCC+0.3	V	
VOL	Output Low Voltage	-	0.4	V	IO = 3.2mA
VOH	Output High Voltage	2.4	-	V	IO = -0.4mA

Capacitance

SYMBOL	PARAMETER	MAX	UNITS	TEST CONDITIONS
CI	Input Capacitance (Note 2)	6	pF	VI = VCC or GND, f = 1MHz
CO	Output Capacitance (Note 2)	10	pF	VO = VCC or GND, f = 1MHz

NOTES:

- Input pulse levels: 0 to 3.0V; Input rise and fall times: 5ns (max); Input and output timing reference level: 1.5V; Output load: 1 TTL gate equivalent CL = 50pF (min) - for CL greater than 50pF, access time is derated by 0.15ns per pF.
- Tested at initial design and after major design changes.
- Typical derating 1.5mA/MHz increase in ICCOP.
- VCC = 4.5V and 5.5V.

2
 CMOS MEMORY

Specifications HM-6508B-8/HM-6508B-9

T-46-23-05

A.C. Electrical Specifications VCC = 5V ± 10%; T_A = HM-6508B-9 -40°C to +85°C
 T_A = HM-6508B-8 -55°C to +125°C

SYMBOL	PARAMETER	MIN	MAX	UNITS	TEST CONDITIONS
(1) TELQV	Chip Enable Access Time	-	180	ns	(Notes 1, 4)
(2) TAVQV	Address Access Time	-	180	ns	(Notes 1, 4)
(3) TELQX	Chip Enable Output Enable Time	5	120	ns	(Notes 2, 4)
(4) TWLQZ	Write Enable Output Disable Time	-	120	ns	(Notes 2, 4)
(5) TEHQZ	Chip Enable Output Disable Time	-	120	ns	(Notes 2, 4)
(6) TELEH	Chip Enable Pulse Negative Width	180	-	ns	(Notes 1, 4)
(7) TEHEL	Chip Enable Pulse Positive Width	100	-	ns	(Notes 1, 4)
(8) TAVEL	Address Setup Time	0	-	ns	(Notes 1, 4)
(9) TELAX	Address Hold Time	40	-	ns	(Notes 1, 4)
(10) TDVWH	Data Setup Time	80	-	ns	(Notes 1, 4)
(11) TWHDX	Data Hold Time	0	-	ns	(Notes 1, 4)
(12) TWLEH	Chip Enable Write Pulse Setup Time	100	-	ns	(Notes 1, 4)
(13) TELWH	Chip Enable Write Pulse Hold Time	100	-	ns	(Notes 1, 4)
(14) TWLWH	Write Enable Pulse Width	100	-	ns	(Notes 1, 4)
(15) TELEL	Read or Write Cycle Time	280	-	ns	(Notes 1, 4)

NOTES:

- Input pulse levels: 0 to 3.0V; Input rise and fall times: 5ns (max); Input and output timing reference level: 1.5V; Output load: 1 TTL gate equivalent CL = 50pF (min) - for CL greater than 50pF, access time is derated by 0.15ns per pF.
- Tested at initial design and after major design changes.
- Typical derating 1.5mA/MHz increase in ICCOP.
- VCC = 4.5V and 5.5V.

T 46-23-05

Specifications HM-6508-8/HM-6508-9

HM-6508

Absolute Maximum Ratings

Supply Voltage	+7.0V
Input, Output or I/O Voltage Applied	GND -0.3V to VCC +0.3V
Storage Temperature Range	-65°C to +150°C
Maximum Package Power Dissipation	1 Watt
θ_{jc}	15°C/W (CERDIP Package)
θ_{ja}	75°C/W (CERDIP Package)
Gate Count	1925 Gates
Junction Temperature	+150°C
Lead Temperature (Soldering, Ten Seconds)	+275°C

CAUTION: Stresses above those listed in the "Absolute Maximum Ratings" may cause permanent damage to the device. This is a stress only rating and operation of the device at these or any other conditions above those indicated in the operation section of this specification is not implied.

Operating Conditions

Operating Voltage Range	+4.5V to +5.5V
Operating Temperature Ranges:	
HM-6508-9	-40°C to +85°C
HM-6508-8	-55°C to +125°C

D.C. Electrical Specifications VCC = 5V ± 10%; T_A = HM-6508-9 -40°C to +85°C
 T_A = HM-6508-8 -55°C to +125°C

SYMBOL	PARAMETER	MIN	MAX	UNITS	TEST CONDITIONS
ICCSB	Standby Supply Current	-	10	µA	IO = 0, VI = VCC or GND
ICCOP	Operating Supply Current (Note 3)	-	4	mA	\bar{E} = 1MHz, IO = 0, VI = VCC or GND
ICCDR	Data Retention Supply Current	-	10	µA	VCC = 2.0, IO = 0, VI = VCC or GND E = VCC
VCCDR	Data Retention Supply Voltage	2.0	-	V	
II	Input Leakage Current	-1.0	+1.0	µA	VI = VCC or GND
IOZ	Output Leakage Current	-1.0	+1.0	µA	VO = VCC or GND
VIL	Input Low Voltage	-0.3	0.8	V	
VIH	Input High Voltage	VCC-2.0	VCC+0.3	V	
VOL	Output Low Voltage	-	0.4	V	IO = 3.2mA
VOH	Output High Voltage	2.4	-	V	IO = -0.4mA

Capacitance

SYMBOL	PARAMETER	MAX	UNITS	TEST CONDITIONS
CI	Input Capacitance (Note 2)	6	pF	VI = VCC or GND, f = 1MHz
CO	Output Capacitance (Note 2)	10	pF	VO = VCC or GND, f = 1MHz

- NOTES:
- Input pulse levels: 0 to 3.0V; Input rise and fall times: 5ns (max); Input and output timing reference level: 1.5V; Output load: 1 TTL gate equivalent CL = 50pF (min) - for CL greater than 50pF, access time is derated by 0.15ns per pF.
 - Tested at initial design and after major design changes.
 - Typical derating 1.5mA/MHz increase in ICCOP.
 - VCC = 4.5V and 5.5V.

2
CMOS MEMORY

Specifications HM-6508-8/HM-6508-9

T-46-23-05

A.C. Electrical Specifications VCC = 5V ± 10%; T_A = HM-6508-9 -40°C to +85°C
 T_A = HM-6508-8 -55°C to +125°C

SYMBOL	PARAMETER	MIN	MAX	UNITS	TEST CONDITIONS
(1) TELQV	Chip Enable Access Time	-	250	ns	(Notes 1, 4)
(2) TAVQV	Address Access Time	-	250	ns	(Notes 1, 4)
(3) TELQX	Chip Enable Output Enable Time	5	160	ns	(Notes 2, 4)
(4) TWLQZ	Write Enable Output Disable Time	-	160	ns	(Notes 2, 4)
(5) TEHQZ	Chip Enable Output Disable Time	-	160	ns	(Notes 2, 4)
(6) TELEH	Chip Enable Pulse Negative Width	250	-	ns	(Notes 1, 4)
(7) TEHEL	Chip Enable Pulse Positive Width	100	-	ns	(Notes 1, 4)
(8) TAVEL	Address Setup Time	0	-	ns	(Notes 1, 4)
(9) TELAX	Address Hold Time	50	-	ns	(Notes 1, 4)
(10) TDVWH	Data Setup Time	110	-	ns	(Notes 1, 4)
(11) TWHDX	Data Hold Time	0	-	ns	(Notes 1, 4)
(12) TWLEH	Chip Enable Write Pulse Setup Time	130	-	ns	(Notes 1, 4)
(13) TELWH	Chip Enable Write Pulse Hold Time	130	-	ns	(Notes 1, 4)
(14) TWLWH	Write Enable Pulse Width	130	-	ns	(Notes 1, 4)
(15) TELEL	Read or Write Cycle Time	350	-	ns	(Notes 1, 4)

NOTES:

- Input pulse levels: 0 to 3.0V; Input rise and fall times: 5ns (max); Input and output timing reference level: 1.5V; Output load: 1 TTL gate equivalent CL = 50pF (min) - for CL greater than 50pF, access time is derated by 0.15ns per pF.
- Tested at initial design and after major design changes.
- Typical derating 1.5mA/MHz increase in ICCOP.
- VCC = 4.5V and 5.5V.

T 46-23-05

Specifications HM-6508-5

HM-6508

Absolute Maximum Ratings

Supply Voltage	+7.0V
Input, Output or I/O Voltage Applied	GND -0.3V to VCC +0.3V
Storage Temperature Range	-65°C to +150°C
Maximum Package Power Dissipation	1 Watt
θ_{jc}	15°C/W (CERDIP Package)
θ_{ja}	75°C/W (CERDIP Package)
Gate Count	1925 Gates
Junction Temperature	+150°C
Lead Temperature (Soldering, Ten Seconds)	+275°C

CAUTION: Stresses above those listed in the "Absolute Maximum Ratings" may cause permanent damage to the device. This is a stress only rating and operation of the device at these or any other conditions above those indicated in the operation section of this specification is not implied.

Operating Conditions

Operating Voltage Range	+4.5V to +5.5V
Operating Temperature Ranges: HM-6508-5	0°C to +70°C

D.C. Electrical Specifications VCC = 5V ± 10%; TA = HM-6508-5 0°C to +70°C

SYMBOL	PARAMETER	MIN	MAX	UNITS	TEST CONDITIONS
ICCSB	Standby Supply Current	-	100	µA	IO = 0, VI = VCC or GND
ICCOP	Operating Supply Current (Note 3)	-	4	mA	\bar{E} = 1MHz, IO = 0, VI = VCC or GND
ICCDR	Data Retention Supply Current	-	100	µA	VCC = 2.0, IO = 0, VI = VCC or GND \bar{E} = VCC
VCCDR	Data Retention Supply Voltage	2.0	-	V	
II	Input Leakage Current	-1.0	+1.0	µA	VI = VCC or GND
IOZ	Output Leakage Current	-1.0	+1.0	µA	VO = VCC or GND
VIL	Input Low Voltage	-0.3	0.8	V	
VIH	Input High Voltage	VCC-2.0	VCC+0.3	V	
VOL	Output Low Voltage	-	0.4	V	IO = 1.6mA
VOH	Output High Voltage	2.4	-	V	IO = -0.2mA

Capacitance

SYMBOL	PARAMETER	MAX	UNITS	TEST CONDITIONS
CI	Input Capacitance (Note 2)	6	pF	VI = VCC or GND, f = 1MHz
CO	Output Capacitance (Note 2)	10	pF	VO = VCC or GND, f = 1MHz

NOTES:

- Input pulse levels: 0 to 3.0V; Input rise and fall times: 5ns (max); Input and output timing reference level: 1.5V; Output load: 1 TTL gate equivalent CL = 50pF (min) - for CL greater than 50pF, access time is derated by 0.15ns per pF.
- Tested at initial design and after major design changes.
- Typical derating 1.5mA/MHz increase in ICCOP.
- VCC = 4.5V and 5.5V.

2
CMOS
MEMORY

T.46.23-05

Specifications HM-6508-5**A.C. Electrical Specifications** VCC = 5V ± 10%; T_A = HM-6508-5 0°C to +70°C

SYMBOL	PARAMETER	MIN	MAX	UNITS	TEST CONDITIONS
(1) TELQV	Chip Enable Access Time	-	300	ns	(Notes 1, 4)
(2) TAVQV	Address Access Time	-	310	ns	(Notes 1, 4)
(3) TELQX	Chip Enable Output Enable Time	5	200	ns	(Notes 2, 4)
(4) TWLQZ	Write Enable Output Disable Time	-	200	ns	(Notes 2, 4)
(5) TEHQZ	Chip Enable Output Disable Time	-	200	ns	(Notes 2, 4)
(6) TELEH	Chip Enable Pulse Negative Width	300	-	ns	(Notes 1, 4)
(7) TEHEL	Chip Enable Pulse Positive Width	150	-	ns	(Notes 1, 4)
(8) TAVEL	Address Setup Time	10	-	ns	(Notes 1, 4)
(9) TELAX	Address Hold Time	70	-	ns	(Notes 1, 4)
(10) TDVWH	Data Setup Time	130	-	ns	(Notes 1, 4)
(11) TWHDX	Data Hold Time	0	-	ns	(Notes 1, 4)
(12) TWLEH	Chip Enable Write Pulse Setup Time	160	-	ns	(Notes 1, 4)
(13) TELWH	Chip Enable Write Pulse Hold Time	160	-	ns	(Notes 1, 4)
(14) TWLWH	Write Enable Pulse Width	160	-	ns	(Notes 1, 4)
(15) TELEL	Read or Write Cycle Time	450	-	ns	(Notes 1, 4)

NOTES:

1. Input pulse levels: 0 to 3.0V; Input rise and fall times: 5ns (max); Input and output timing reference level: 1.5V; Output load: 1 TTL gate equivalent CL = 50pF (min) - for CL greater than 50pF, access time is derated by 0.15ns per pF.
2. Tested at initial design and after major design changes.
3. Typical derating 1.5mA/MHz increase in ICCOP.
4. VCC = 4.5V and 5.5V.

T-46-23-05

HM-6508

HM-6508

Read Cycle

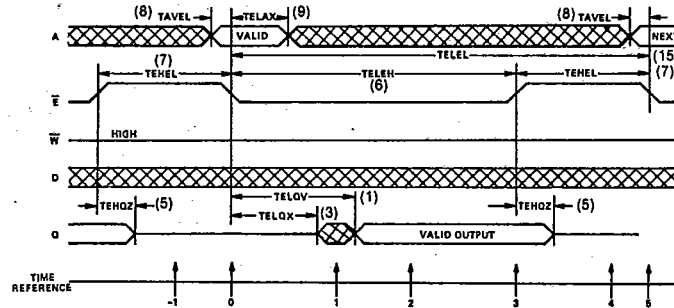

TRUTH TABLE

TIME REFERENCE	\bar{E}	\bar{W}	A	D	Q	FUNCTION
-1	H	X	X	X	Z	Memory Disabled
0	L	H	V	X	Z	Cycle Begins, Addresses are Latched
1	L	H	X	X	X	Output Enabled
2	L	H	X	X	V	Output Valid
3	H	H	X	X	V	Read Accomplished
4	H	X	X	X	Z	Prepare for Next Cycle (Same as -1)
5	L	H	V	X	Z	Cycle Ends, Next Cycle Begins (Same as 0)

In the HM-6508 Read Cycle, the address information is latched into the on chip registers on the falling edge of \bar{E} (T = 0). Minimum address setup and hold time requirements must be met. After the required hold time, the addresses may change state without affecting device operation. During time (T = 1) the data output becomes

enabled; however, the data is not valid until during time (T = 2). \bar{W} must remain high for the read cycle. After the output data has been read, \bar{E} may return high (T = 3). This will disable the chip and force the output buffer to a high impedance state. After the required \bar{E} high time (TEHEL) the RAM is ready for the next memory cycle (T = 4).

Write Cycle

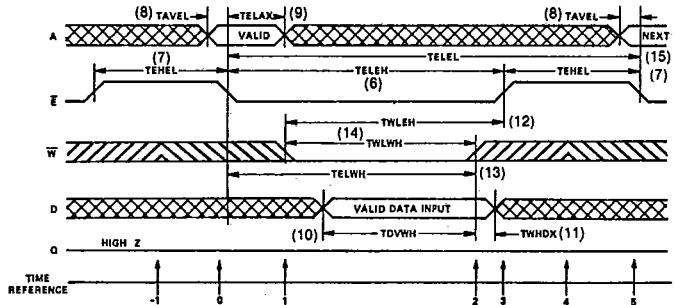

TRUTH TABLE

TIME REFERENCE	\bar{E}	\bar{W}	A	D	Q	FUNCTION
-1	H	X	X	X	Z	Memory Disabled
0	L	X	V	X	Z	Cycle Begins, Addresses are Latched
1	L	L	X	X	Z	Write Period Begins
2	L	H	X	V	Z	Data is Written
3	H	H	X	X	Z	Write Completed
4	H	X	X	X	Z	Prepare for Next Cycle (Same as -1)
5	L	X	V	X	Z	Cycle Ends, Next Cycle Begins (Same as 0)

2
CMOS MEMORY

T46-23-05

HM-6508

The write cycle is initiated by the falling edge of \bar{E} which latches the address information into the on chip registers. The write portion of the cycle is defined as both \bar{E} and \bar{W} being low simultaneously. \bar{W} may go low anytime during the cycle provided that the write enable pulse setup time (TWLEH) is met. The write portion of the cycle is terminated by the first rising edge of either \bar{E} or \bar{W} . Data setup and hold times must be referenced to the terminating signal.

If a series of consecutive write cycles are to be performed, the \bar{W} line may remain low until all desired locations have been written. When this method is used, data setup and hold times must be referenced to the rising edge of \bar{E} . By

positioning the \bar{W} pulse at different times within the \bar{E} low time (TELEH), various types of write cycles may be performed.

If the \bar{E} low time (TELEH) is greater than the \bar{W} pulse (TWLWH) plus an output enable time (TELQX), a combination read write cycle is executed. Data may be modified an indefinite number of times during any write cycle (TELEH). The data input and data output pins may be tied together for use with a common I/O data bus structure. When using the RAM in this method allow a minimum of one output disable time (TWLQZ) after \bar{W} goes low before applying input data to the bus. This will insure that the output buffers are not active.