

## LM1877 Dual Audio Power Amplifier

### General Description

The LM1877 is a monolithic dual power amplifier designed to deliver 2W/channel continuous into 8Ω loads. The LM1877 is designed to operate with a low number of external components, and still provide flexibility for use in stereo phonographs, tape recorders and AM-FM stereo receivers, etc. Each power amplifier is biased from a common internal regulator to provide high power supply rejection, and output Q point centering. The LM1877 is internally compensated for all gains greater than 10.

- Wide supply range, 6V–24V
- Very low cross-over distortion
- Low audio band noise
- AC short circuit protected
- Internal thermal shutdown

### Applications

- Multi-channel audio systems
- Stereo phonographs
- Tape recorders and players
- AM-FM radio receivers
- Servo amplifiers
- Intercom systems
- Automotive products

### Features

- 2W/channel
- –65 dB ripple rejection, output referred
- –65 dB channel separation, output referred

### Connection Diagram

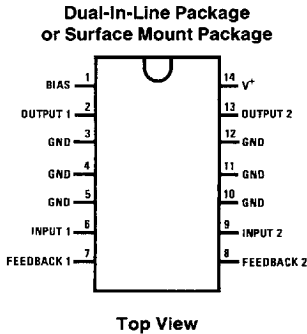

TL/H/7913-1

Order Number LM1877M-9 or LM1877N-9  
See NS Package Number M14B or N14A

### Equivalent Schematic Diagram

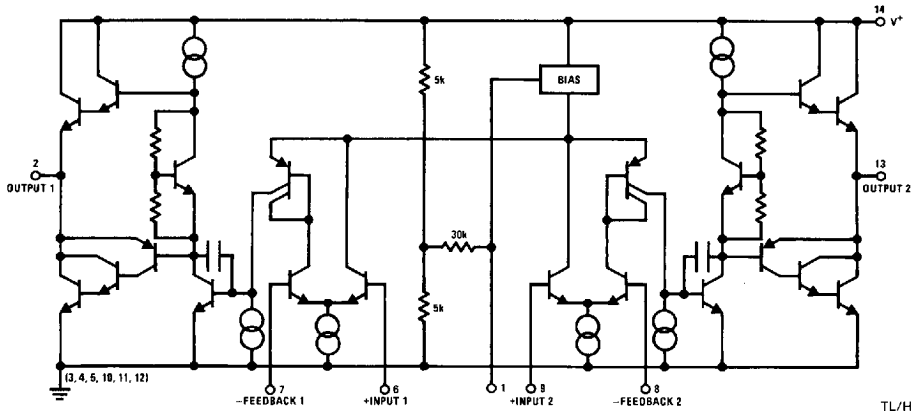

1-73

6501124 0091546 047

## Absolute Maximum Ratings

If Military/Aerospace specified devices are required, please contact the National Semiconductor Sales Office/Distributors for availability and specifications.

Supply Voltage	26V
Input Voltage	±0.7V
Operating Temperature	0°C to +70°C
Storage Temperature	-65°C to +150°C
Junction Temperature	150°C

Lead Temperature	
N-Package Soldering (10 sec.)	260°C
M-Package Infrared (15 sec.)	220°C
M-Package Vapor Phase (60 sec.)	215°C
Thermal Resistance,	
$\theta_{JC}$ (N-Package)	30°C/W
$\theta_{JA}$ (N-Package)	79°C/W
$\theta_{JC}$ (M-Package)	27°C/W
$\theta_{JA}$ (M-Package)	114°C/W

## Electrical Characteristics

$V_S = 20V$ ,  $T_A = 25^\circ C$ , (See Note 1)  $R_L = 8\Omega$ ,  $A_V = 50$  (34 dB) unless otherwise specified

Parameter	Conditions	Min	Typ	Max	Units
Total Supply Current	$P_O = 0W$		25	50	mA
Output Power LM1877	THD = 10% $V_S = 20V$ , $R_L = 8\Omega$ $V_S = 12V$ , $R_L = 8\Omega$	2.0	1.3		W/Ch W/Ch
Total Harmonic Distortion LM1877	$f = 1\text{ kHz}$ , $V_S = 14V$				
	$P_O = 50\text{ mW/Channel}$		0.075		%
	$P_O = 500\text{ mW/Channel}$		0.045		%
	$P_O = 1\text{ W/Channel}$		0.055		%
Output Swing	$R_L = 8\Omega$		$V_S - 6$		Vp-p
Channel Separation	$C_F = 50\ \mu F$ , $C_{IN} = 0.1\ \mu F$ , $f = 1\text{ kHz}$ , Output Referred				
	$V_S = 20V$ , $V_O = 4\text{ Vrms}$	-50	-70		dB
	$V_S = 7V$ , $V_O = 0.5\text{ Vrms}$		-60		dB
PSRR Power Supply Rejection Ratio	$C_F = 50\ \mu F$ , $C_{IN} = 0.1\ \mu F$ , $f = 120\text{ Hz}$ , Output Referred				
	$V_S = 20V$ , $V_{RIPPLE} = 1\text{ Vrms}$	-50	-65		dB
	$V_S = 7V$ , $V_{RIPPLE} = 0.5\text{ Vrms}$		-40		dB
Noise	Equivalent Input Noise				
	$R_S = 0$ , $C_{IN} = 0.1\ \mu F$ , $BW = 20\text{ Hz} - 20\text{ kHz}$ , Output Noise Wideband		2.5		$\mu V$
	$R_S = 0$ , $C_N = 0.1\ \mu F$ , $A_V = 200$		0.80		mV
Open Loop Gain	$R_S = 0$ , $f = 100\text{ kHz}$ , $R_L = 8\Omega$		70		dB
Input Offset Voltage			15		mV
Input Bias Current			50		nA
Input Impedance	Open Loop		4		M $\Omega$
DC Output Level	$V_S = 20V$	9	10	11	V
Slew Rate			2.0		V/ $\mu s$
Power Bandwidth			65		kHz
Current Limit			1.0		A

Note 1: For operation at ambient temperature greater than 25°C, the LM1877 must be derated based on a maximum 150°C junction temperature.

# Typical Performance Characteristics

**Device Dissipation vs Ambient Temperature**

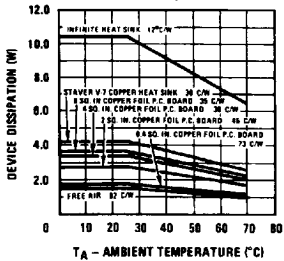

**Power Supply Rejection Ratio (Referred to the Output) vs Frequency**

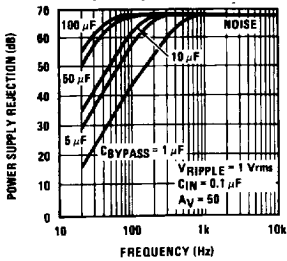

**Power Supply Rejection Ratio (Referred to the Output) vs Frequency**

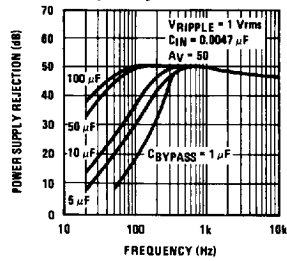

**Power Supply Rejection Ratio (Referred to the Output) vs Supply Voltage**

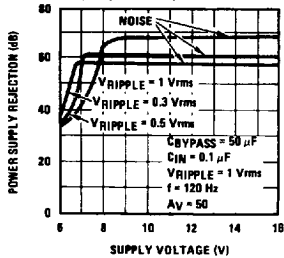

**Channel Separation (Referred to the Output) vs Frequency**

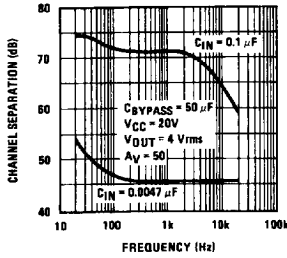

**Channel Separation (Referred to the Output) vs Frequency**

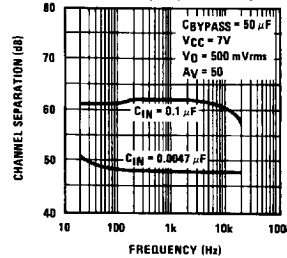

**Average Supply Current vs POUT**

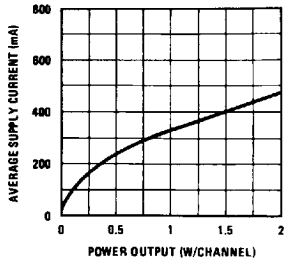

**Total Harmonic Distortion vs Frequency**

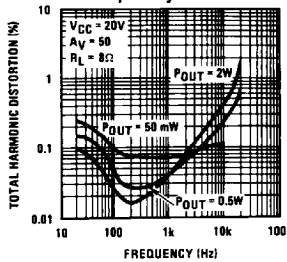

**Total Harmonic Distortion vs Frequency**

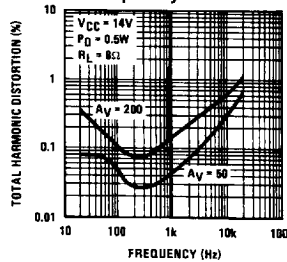

**Power Dissipation (W) Both Channels Operating**

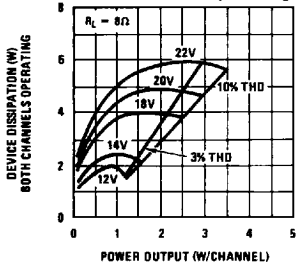

**Open Loop Gain vs Frequency**

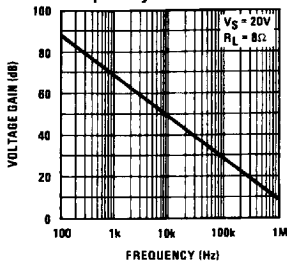

**Output Swing vs Supply Voltage**

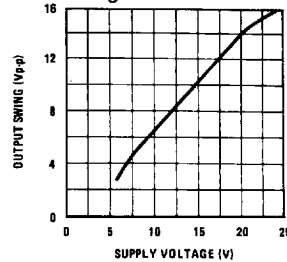

TL/H/7913-3

1

6501124 0091548 91T

# Typical Applications

**Stereo Phonograph Amplifier with Bass Tone Control**

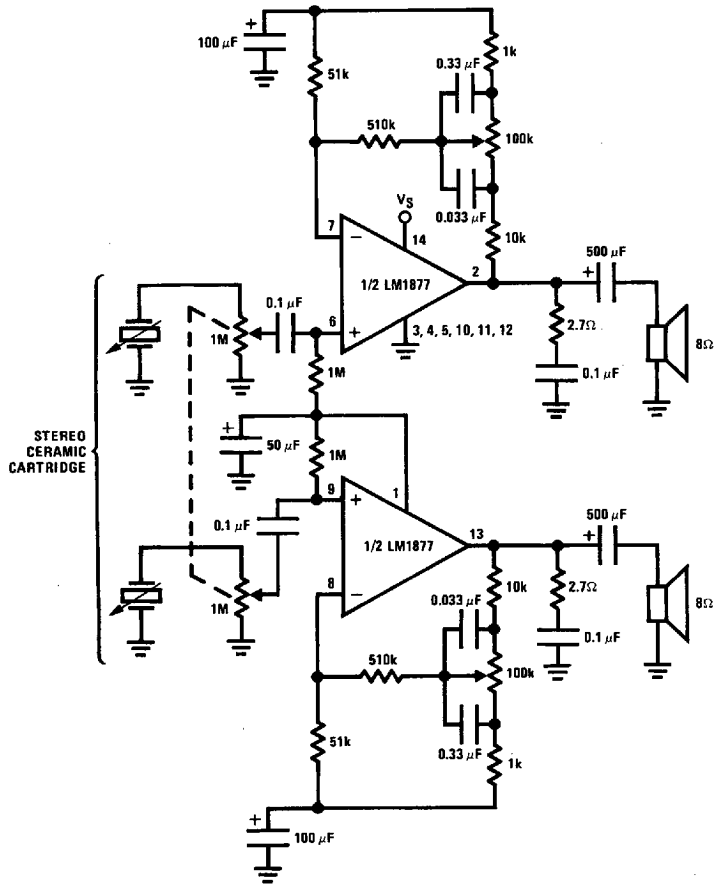

TL/H/7913-4

**Frequency Response of Bass Tone Control**

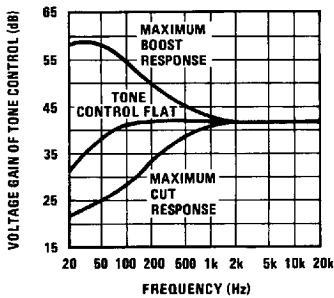

TL/H/7913-5

**Inverting Unity Gain Amplifier**

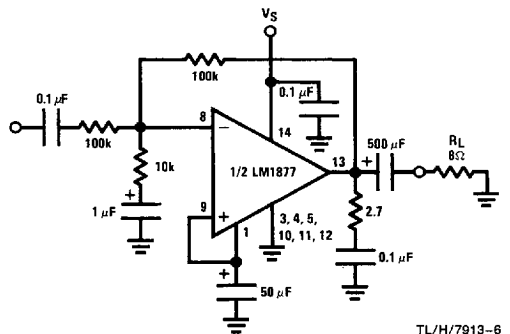

TL/H/7913-6

Typical Applications (Continued)

Stereo Amplifier with  $A_v = 200$

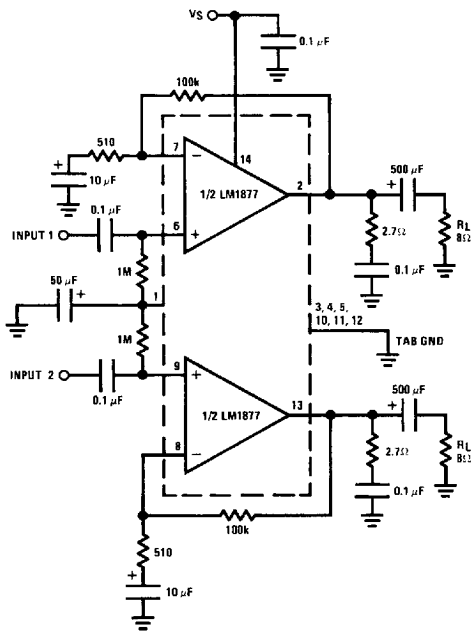

TL/H/7913-7

Non-Inverting Amplifier Using Split Supply

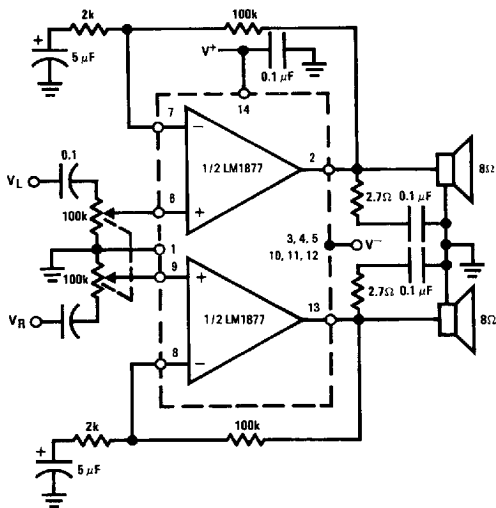

TL/H/7913-8

Typical Split Supply

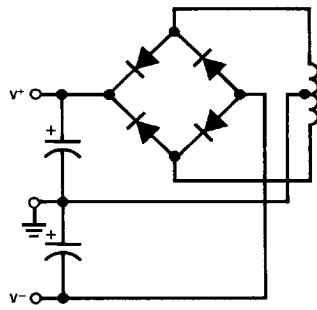

TL/H/7913-9