

V _{RSM} V _{RSM}	I _F RMS (maximum values for continuous operation)					
	80 A			150 A		
V	I _{FAV} (sin. 180; T _{case} = . . .)					
	50 A (118 °C)			95 A (100 °C)		
200	SKN45/02	SKR45/02	SKN70/02	SKR70/02	SKN71/02*	SKR71/02*
400	SKN45/04	SKR45/04	SKN70/04	SKR70/04	SKN71/04*	SKR71/04*
800	SKN45/08	SKR45/08	SKN70/08	SKR70/08	SKN71/08*	SKR71/08*
1200	SKN45/12	SKR45/12	SKN70/12	SKR70/12	SKN71/12*	SKR71/12*
1400	SKN45/14	SKR45/14	SKN70/14	SKR70/14	SKN71/14*	SKR71/14*
1600	SKN45/16	SKR45/16	SKN70/16	SKR70/16	SKN71/16*	SKR71/16*

Rectifier Diodes

SKN 45 **SKR 45**
SKN 70 **SKR 70**
SKN 71 **SKR 71**



Features

- Reverse voltages up to 1600 V
- Hermetic metal cases with glass insulators
- Threaded studs ISO M8 (SKN/R 71 also 1/4-28 UNF)
- **SKN**: anode to stud
SKR: cathode to stud

Typical Applications

- All-purpose mean power rectifier diodes
- Cooling via heatsinks
- Non-controllable and half-controllable rectifiers
- Free-wheeling diodes

Symbol	Conditions	SKN 45 SKR 45	SKN 70 SKR 70	SKN 71 SKR 71
I _{FAV}	sin. 180; T _{case} = 100 °C = 118 °C = 125 °C	50 A 45 A	95 A 70 A	
I _{FSM}	T _{vj} = 25 °C; 10 ms T _{vj} = 180 °C; 10 ms	700 A 600 A	1150 A 1000 A	
i ² t	T _{vj} = 25 °C; 8,3 ... 10 ms T _{vj} = 180 °C; 8,3 ... 10 ms	2500 A ² s 1800 A ² s	6600 A ² s 5000 A ² s	
Q _{rr}	T _{vj} = 160 °C; - $\frac{di_F}{dt} = 10 \frac{A}{\mu s}$	typ. 70 μC	typ. 70 μC	
I _R	T _{vj} = 25 °C; V _R = V _{RSM} T _{vj} = 180 °C; V _R = V _{RSM}	0,6 mA 10 mA	0,6 mA 10 mA	
V _F	T _{vj} = 25 °C; (I _F = . . .); max.	1,6 V (150 A)	1,5 V (200 A)	
V _(TO)	T _{vj} = 180 °C	0,85 V	0,85 V	
r _T	T _{vj} = 180 °C	5 mΩ	3 mΩ	
R _{thjc}		0,85 °C/W	0,55 °C/W	
R _{thch}		0,25 °C/W	0,2 °C/W	
T _{vj}		- 40 ... + 180 °C		
T _{stg}		- 55 ... + 180 °C		
M	M 8 } SI units/ 1/4-28 UNF 2 A } US units	4 Nm/35 lb. in. 2,5 Nm/22 lb. in.		
a		5 · 9,81 m/s ²		
w	approx.	30 g		
RC	(P _R = . . .)	0,1 μ +100 Ω (1 W)	0,1 μF +100 Ω (2 W)	
R _p	P _R = 6 W	80 kΩ	80 kΩ	
Case		E 12	E 12	E 11

* available with UNF thread 1/4-28 UNF 2 A; e.g. SKN 71/02 UNF

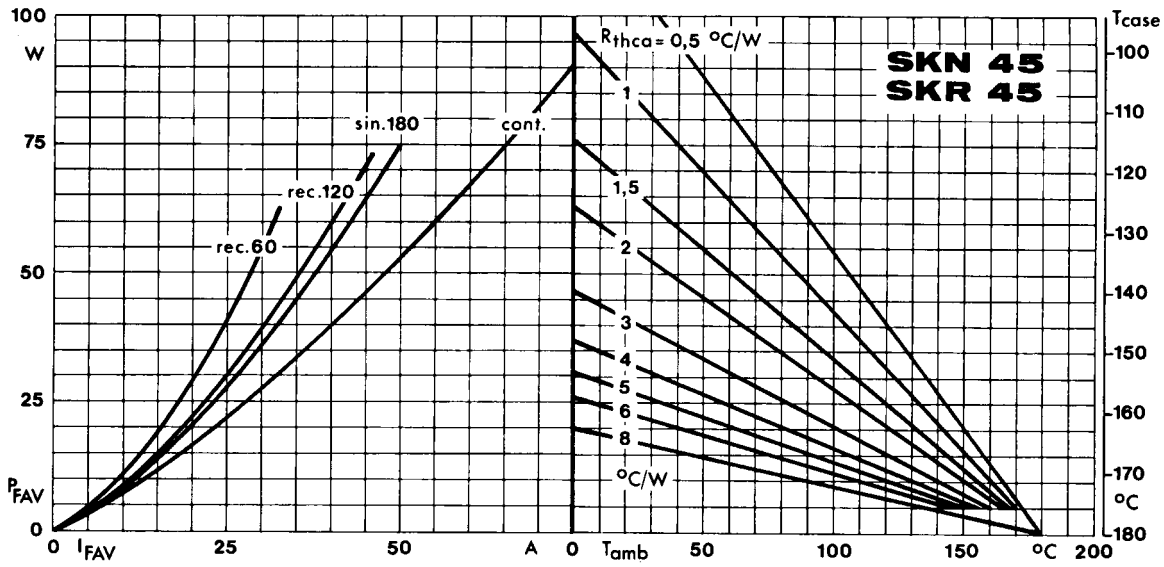

Fig. 1 a Power dissipation vs. forward current and case temperature

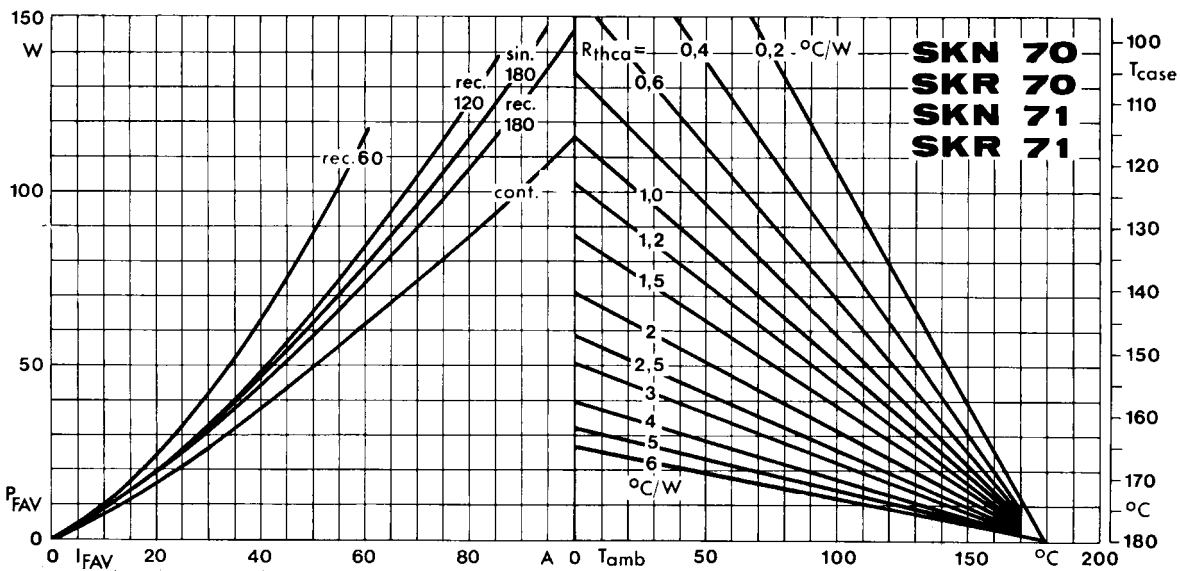

Fig. 1 b Power dissipation vs. forward current and case temperature

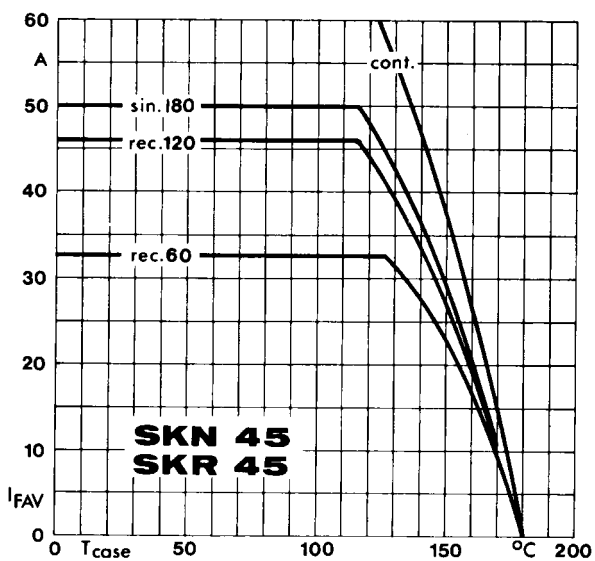

Fig. 3 a Rated forward current vs. case temperature

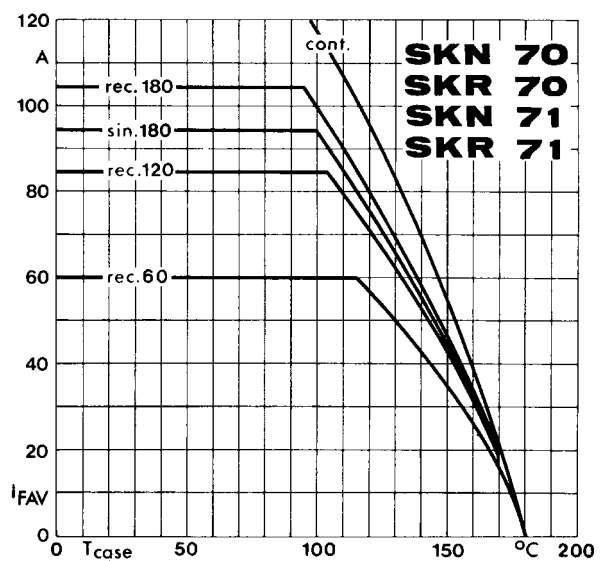

Fig. 3 b Rated forward current vs. case temperature

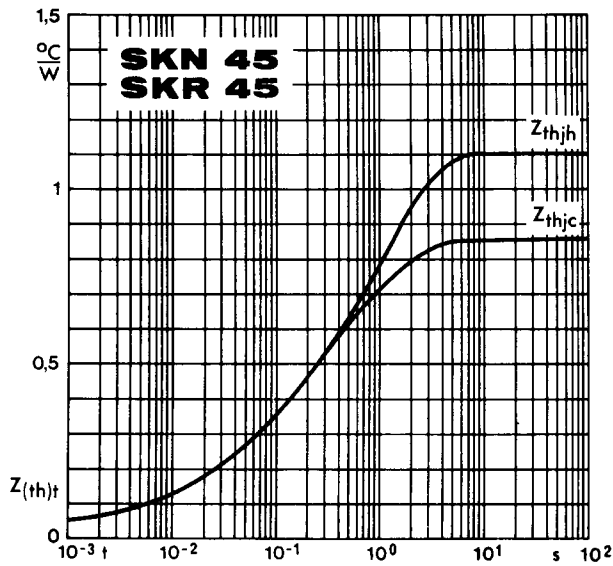

Fig. 5 a Transient thermal impedance vs. time

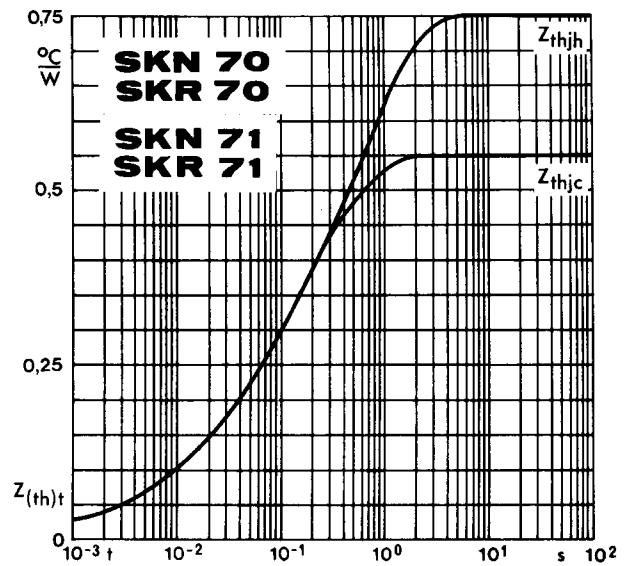

Fig. 5 b Transient thermal impedance vs. time

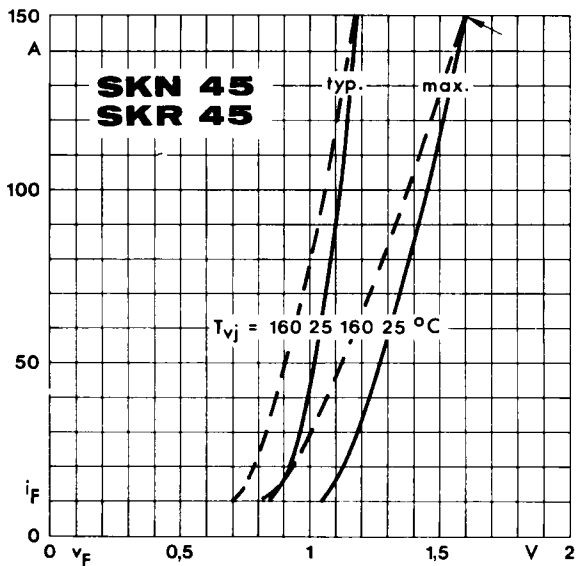

Fig. 6 a Forward characteristics

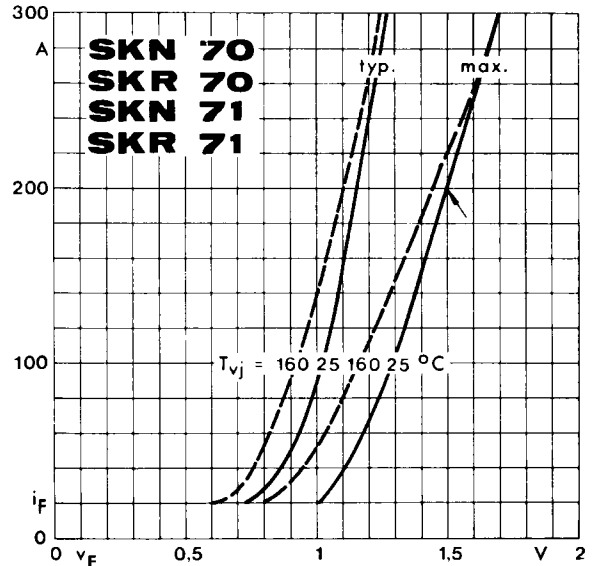

Fig. 6 b Forward characteristics

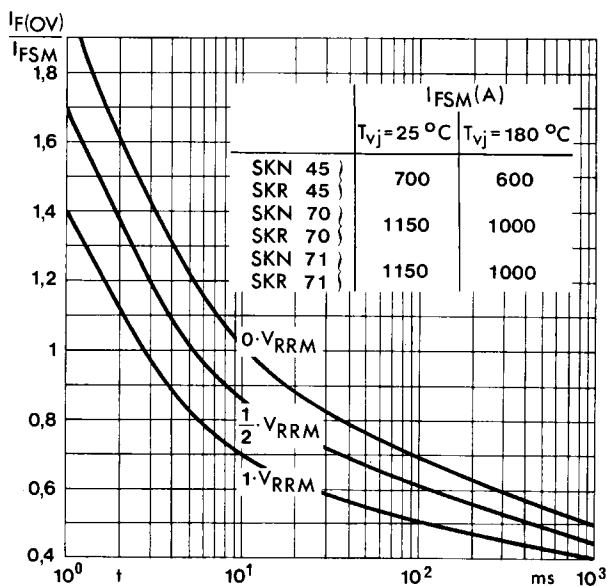
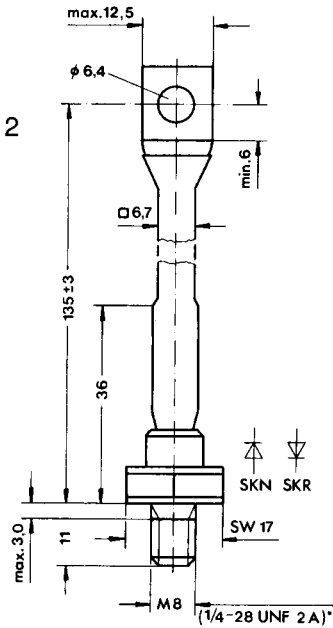

Fig. 7 Surge overload current vs. time

**SKN 45, SKR 45
SKN 70, SKR 70**

Case E 12

IEC: A 16 U; A 17 M B 2
DIN 41 886: 103 A 2
BS 3934: SO-32 A,
SO-32 B



**SKN 71
SKR 71**

Case E 11

IEC: A 16 U; A 17 M B 2
DIN 41 886: 103 A 2
BS 3934: SO-32 A,
SO-32 B
JEDEC: DO-203 AB
(DO-5)

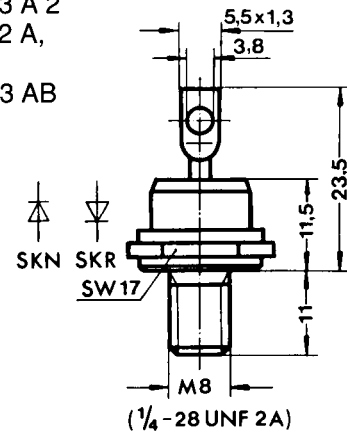

**SKN 100
SKR 100**

Case E 13

IEC: A 9 MA¹⁾
DIN 41 887: 105 B 2¹⁾
BS 3934: SO-29 B
JEDEC: DO-205 AC

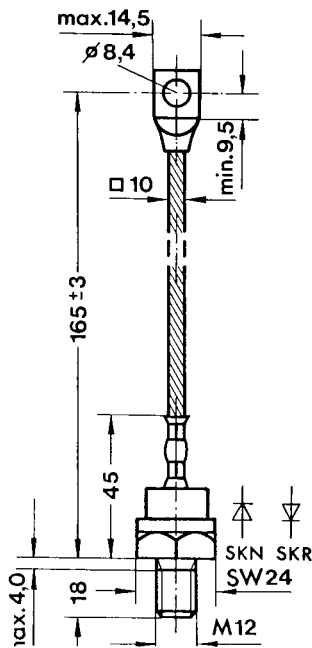

**SKN 130
SKR 130**

Case E 14

IEC: A 9 MA¹⁾
DIN 41 887: 105 B 2¹⁾
BS 3934: SO-29 B
JEDEC: DO-205 AC
(DO-30)²⁾

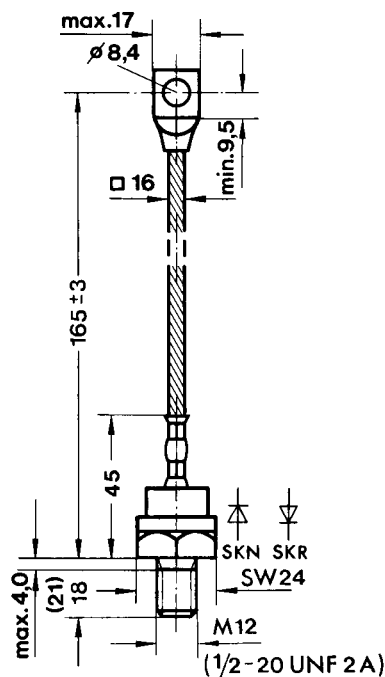

**SKN 240
SKR 240**

Case E 15

IEC: A 15 M
DIN 41 887: 106 B 2
BS 3934: SO-42
JEDEC: DO-205 AB
(DO-9)

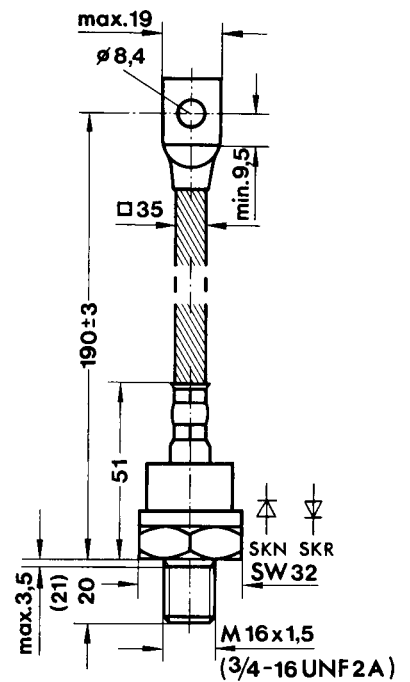

¹⁾ modified

²⁾ available with thread 1/2-20 UNF 2 A or 3/8-28 UNF 2 A

Dimensions in mm