

WESTERN DIGITAL

C O R P O R A T I O N

WD9918/WD9928/WD9929 Video Display Processors

WD9918/9928/9929

FEATURES

- SINGLE-CHIP SOLUTION FOR INTERFACING COLOR TVS [EXCLUDING RANDOM-ACCESS MEMORY (RAM) AND RADIO FREQUENCY (RF) MODULATOR (WD9918 ONLY)]
- 256 X 192 RESOLUTION ON TV SCREEN
- 15 UNIQUE COLORS PLUS TRANSPARENT
- GENERAL 8-BIT BIDIRECTIONAL INTERFACE TO CENTRAL PROCESSOR UNIT (CPU)
- DIRECT WIRING TO 4K, 8K, OR 16K DYNAMIC RAM MEMORIES
- AUTOMATIC AND TRANSPARENT REFRESH OF DYNAMIC RAMS
- MULTIPLE VDP SYSTEMS CAPABILITY
- EXTERNAL VDP INPUT CAPABILITY (WD9918 ONLY)
- COMPOSITE VIDEO OUTPUT (WD9918 ONLY)
- UNIQUE PLANAR REPRESENTATION FOR 3D SIMULATION
- STANDARD 40-PIN PACKAGE
- COLOR DIFFERENCE OUTPUTS ALLOW RGB DRIVE — WD9928/WD9929
- SINGLE +5 VDC POWER SUPPLY

DESCRIPTION

The WD9918/9928/9929 video display processors (VDP) are N-channel MOS LSI devices used in video systems where data display on a raster-scanned home color television set or color monitor is desired. These devices generate all necessary video, control, and synchronization signals and also control the storage, retrieval, and refresh of display data in the dynamic screen refresh memory. The interfaces to the microprocessor, refresh memory, and the TV require a minimum of additional electronics for the WD9918.

The WD9928/9929 VDPs are functionally identical to the WD9918 except that the NTSC color encoding circuitry has been removed and replaced with luminance and color difference signals. The WD9918 is pin-for-pin compatible with the WD9928/9929, except for three pins, the composite video output, the external video input and the CPU clock output. These pins are replaced with the Black/White luminance and composite sync (Y) output and two color difference pins, Blue (B-Y) and Red (R-T) outputs, respectively. The color difference outputs allow the user to generate Red-Green-Blue (R-G-B) drive for direct color gun control, or composite video for use

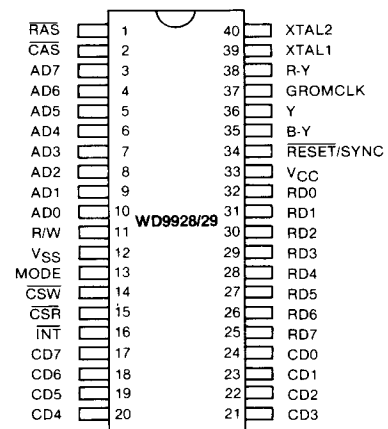
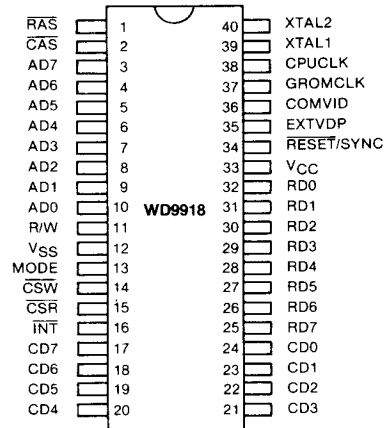

PIN DESIGNATIONS

with NTSC or PAL video color monitor. However, to connect these three outputs to a R-G-B or monitor requires additional R-G-B or encoder circuitry.

The WD9918/9928 have a 525-line format for U.S. televisions while the WD9929 has a 625-line format for use with the European PAL system.

The VDP has four video display modes: Graphics I, Graphics II, Multicolor and Text mode. The Text mode provides twenty-four 40-character rows in two colors

and is intended to maximize the capacity of the TV screen to display alphanumeric character. The Multicolor mode provides an unrestricted 64 x 48 color-dot display employing 15 colors plus transparent. The Graphics I mode provides a 256 x 192 pixel display for generating pattern graphics in 15 colors plus transparent. The Graphics II mode is an enhancement of Graphics I mode, allowing it to generate more complex color and pattern displays.

The video display consists of 35 planes: external VDP, backdrop, pattern plane, and 32 Sprite Planes. The planes are vertically stacked with the external

VDP being the bottom or innermost plane. The backdrop plane is the next plane followed by the pattern plane that contains Graphics I and Graphics II patterns with the 32 Sprite Planes as the top planes.

The WD9918/9928/9929 VDPs use either a 4K, 8K, or 16K-type low-cost dynamic memory for storage of the display parameters.

The WD9918, WD9928, and WD9929 interface identically to the host microprocessor making them software compatible. Thus, all references to VDP in this document apply to all three devices, except where noted.

WD9918/WD9928/WD9929 PIN DESCRIPTIONS

PIN NUMBER	SIGNAL NAME	I/O	DESCRIPTION
1	$\overline{\text{RAS}}$	O	VRAM row address strobe.
2	$\overline{\text{CAS}}$	O	VRAM column address strobe.
3	AD7	O	VRAM address/data bus (multiplexed high and low order VRAM address and output data bytes).†**
4	AD6	O	
5	AD5	O	
6	AD4	O	
7	AD3	O	
8	AD2	O	
9	AD1	O	
10	AD0 MSB	O	AD0 is the most significant bit and is used only for data and not for addressing.**
11	RW	O	VRAM write strobe.
12	VSS	I	Ground References.
13	MODE	I	CPU interface mode select; usually a processor address line.
14	$\overline{\text{CSW}}$	I	CPU-VDP write strobe
15	$\overline{\text{CSR}}$	I	CPU-VDP read strobe
16	$\overline{\text{INT}}$	O	CPU interrupt output.
17	CD7 LSB	I/O	
18	CD6	I/O	
19	CD5	I/O	
20	CD4	I/O	
21	CD3	I/O	
22	CD2	I/O	
23	CD1	I/O	
24	CD0 MSB	I/O	CPU data bus; (CD0) is the most significant bit.
25	RD7	I	
26	RD6	I	
27	RD5	I	
28	RD4	I	

WD9918/WD9928/WD9929 PIN DESCRIPTIONS (Continued)

WD9918/9928/9929

PIN NUMBER	SIGNAL NAME	I/O	DESCRIPTION
29	RD3	I	VRAM read data bus.
30	RD2	I	
31	RD1	I	
32	RD0 MSB	I	
33	V _{CC}	I	+ 5 volt supply.
34	RESET/SYNC	I	The RESET pin is a trilevel input pin. When it is below 0.8 volts, RESET initializes the VDP. When it is above 9 volts, RESET is the synchronizing input for external video.
35	B-Y (WD9928/9929)	I/O	On the WD9928/9929, this is the B-Y color difference output.
35	EXTVDP (WD9918)	I/O	On the WD9918, this is the external VDP input.
36	Y (WD9928/9929)	O	On the WD9928/9929, this is the Y (black/white luminance and composite sync) output.
36	COMVID (WD9918)	O	Composite video output for the WD9918.
37	GROMCLK	O	VDP output clock = XTAL/24 (usage is optional).
38	R-Y (WD9928/9929)	O	On the WD9928/9929, this is the R-Y color difference output.
38	CPUCLK (WD9918)	O	VDP color burst frequency clock (usage is optional).
40, 39	XTAL1, XTAL2	I	10.7 + MHz crystal inputs.*

* When driven externally, both inputs must be driven.
 ** The least significant address bit (AD7) is wired to A0 of the dynamic RAMs. Likewise, AD6 is wired to A1 of the RAMs.
 † Care must be exercised in assuring proper orientation of the WD9918 address outputs to the dynamic RAM address inputs.

TYPICAL APPLICATIONS

- Color computer terminals
- Home computers
- Drafting/design aids
- Teaching aids
- Industrial process monitoring
- Home educational systems
- Animation aids
- European 625-line TV (WD9929 only)

The following example of a typical application may help introduce the user to the WD9918 VDP. Figure 1-1 is a block diagram of a typical application. Each of the concepts presented in the example is described more fully later in this data sheet.

The VDP basically has three interfaces: CPU, color monitor, and dynamic refresh RAM (VRAM), the contents of which define the TV image. The WD9918 also has eight write-only registers and a read-only status register.

The VDP communicates with the CPU via an 8-bit bidirectional data bus. Three control lines, decoded from the CPU address and enable lines, determine interpretation of the bus. Through the bus, the CPU can write to VRAM, read from VRAM, write to VDP registers, and read the VDP status. The VDP also generates an interrupt signal after every refresh of the TV display.

The dynamic RAM interface consists of direct wiring of eight 4K x 1, 8K x 1, or 16K x 1 dynamic RAS/CAS-type RAMs to the VDP. The amount of RAM required is dependent upon the features selected for use in the application.

The interface to the monitor can consist of either wiring the WD9918 composite video output pin (suitably buffered) to the input of a color or black-and-white monitor, or using an appropriate RF modulator to feed the signal into a TV antenna terminal. The WD9928/9929 require additional encoder circuitry to interface to a RGB or to a composite video monitor.

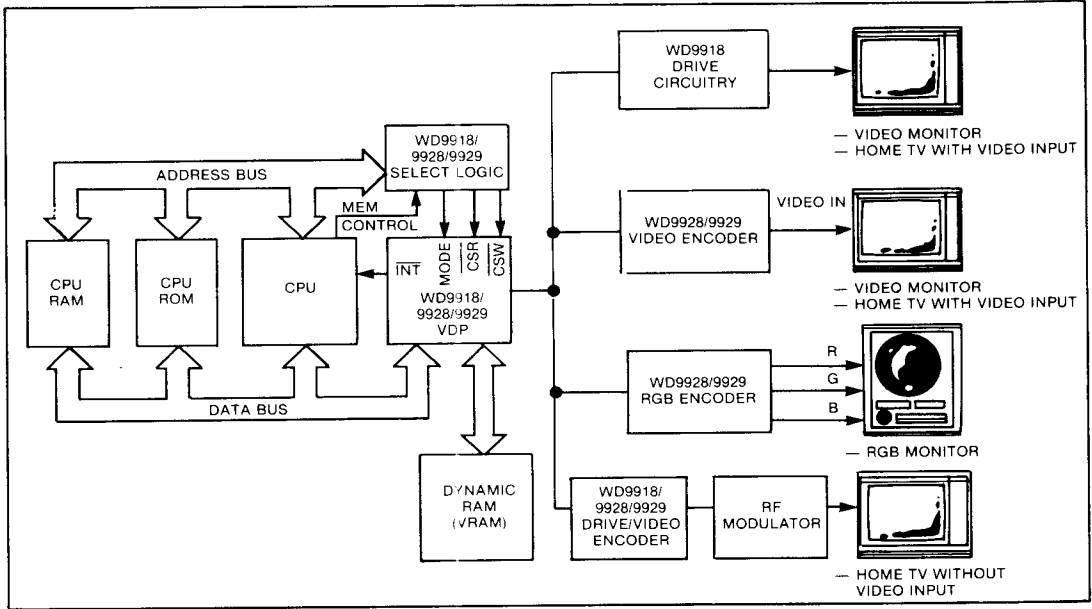

Figure 1. WD9918/28/29 SYSTEM BLOCK DIAGRAM

The VDP operates in four modes, and each one can affect the way the VRAM is mapped onto the television screen. In Graphics I and II modes, characters are mapped onto the screen in 8 x 8 pixel blocks, yielding 24 lines of 32 blocks (pattern positions) each. In Text mode, there are 24 lines of 40 blocks, each of which is 6 x 8 pixels. In Multicolor mode, there are 48

lines of 64 blocks, each of which is composed of 4 x 4 picture elements (pixels), all of one solid color. In addition to these, sprites can be superimposed onto the television image in Graphics I, II, and Multicolor mode. Furthermore, signals entering the WD9918 through the external VDP input can be used as a background to the WD9918.

ACRONYMS AND GLOSSARY

B-Y	Blue color difference output
COMVID (Composite Video)	Contains luminance, chrominance and all sync pulse necessary for horizontal and vertical timing
CAS	Column Address Strobe
CPU	Central Processor Unit
CSR	CPU from VDP read select
CSW	CPU to VDP write select
CPUCLK	XTAL — 3
GROMCLK	XTAL — 24
LSB	Least Significant Bit
LSI	Large Scale Integration
MOS	Metal Oxide Semiconductor
MHz	Megahertz
MSB	Most Significant Bit
NTSC	National Television Standards Committee which specifies television signal standards for the USA
PAL	Phase Alternating Line

Pixel	Picture Element — the smallest point on the TV screen that can be independently controlled
RAM	Random-Access Memory
RAS	Row-Address Strobe
RASTER	The area in which an image is reproduced
RF	Radio Frequency
R-G-B	Red-Green-Blue
ROM	Read-Only Memory
R/W	Read/Write
R-Y	Red color difference output
Sprite	An object whose pattern is relative to a specified X, Y coordinate and whose position can therefore be controlled by that coordinate with a positional resolution of one pixel
VDP	Video Display Processor
VRAM	Video RAM; refers to the dynamic RAMs that connect to the VDP and whose contents define the TV image
Y	Black/white luminance and composite sync

ARCHITECTURE

The WD9918 video display processor (VDP) is designed to provide a simple interface between a microprocessor and a raster-scanned color television. The WD9928/9929 VDPs are designed as a simple interface between a microprocessor, and R-G-B monitor or video encoder which produces the video for a video monitor. Figure 2 is a block diagram of the major portions of the VDP architecture interfaces to the VDP, CPU, VRAM, and color television.

CPU INTERFACE

The VDP interface to the CPU using an 8-bit bidirectional data bus, three control lines, and an interrupt is shown in Figure 3. Through this interface the CPU can conduct four operations:

1. Write data bytes to VRAM
2. Read data bytes from VRAM
3. Write to one of the eight VDP write-only registers
4. Read the VDP Status Register.

Each of these operations requires one or more data transfers to take place over the CPU/VDP data bus interface. The interpretation of the data transfer is determined by the three control lines of the VDP.

NOTE:

The CPU can communicate with the VDP simultaneously and asynchronously with the VDP's TV screen refresh operations. The VDP performs memory management and allows periodic intervals of CPU access to VRAM even in the middle of a raster scan.

CPU INTERFACE CONTROL SIGNALS

The type and direction of data transfers are controlled by the CSW, CSR, and MODE inputs. CSW is

the CPU to VDP write select. When it is active (low), the eight bits on CD0-CD7 are strobed into the VDP. CSR is the CPU from VDP read select. When it is active (low), the VDP outputs eight bits on CD0-CD7 to the CPU. CSW and CSR should never be simultaneously low at the same time. If both are low, the VDP outputs data on CD0-CD7 and latches in invalid data.

MODE determines the source or destination of a read or write data transfer. MODE is normally tied to a CPU low order address line.

CPU WRITE TO VDP REGISTER

The VDP has eight write-only registers and one read-only status register. The write-only registers control the VDP operation and determine the way in which VRAM is allocated. The status register contains interrupt, sprite coincidence and fifth sprite status flags.

Each of the eight VDP write-only registers can be loaded using two 8-bit data transfers from the CPU. Table 1 describes the required format for the two bytes. The first byte transferred is the data byte, and the second byte transferred controls the destination. The MSB of the second byte must be a 1. The next four bits are 0s, and the lowest three bits make up the destination register number. The MODE input is high for both byte transfers.

To rewrite the data in an internal register after a byte of data has already been loaded, the status register must be read so that internal CPU interface logic is reinitialized and will accept the next byte as data and not as a register destination. This situation may be encountered in interrupt-driven program environments. Whenever the status of VDP write parameters is in question, this procedure should be used.

NOTE:

The CPU address is destroyed by writing to the VDP register.

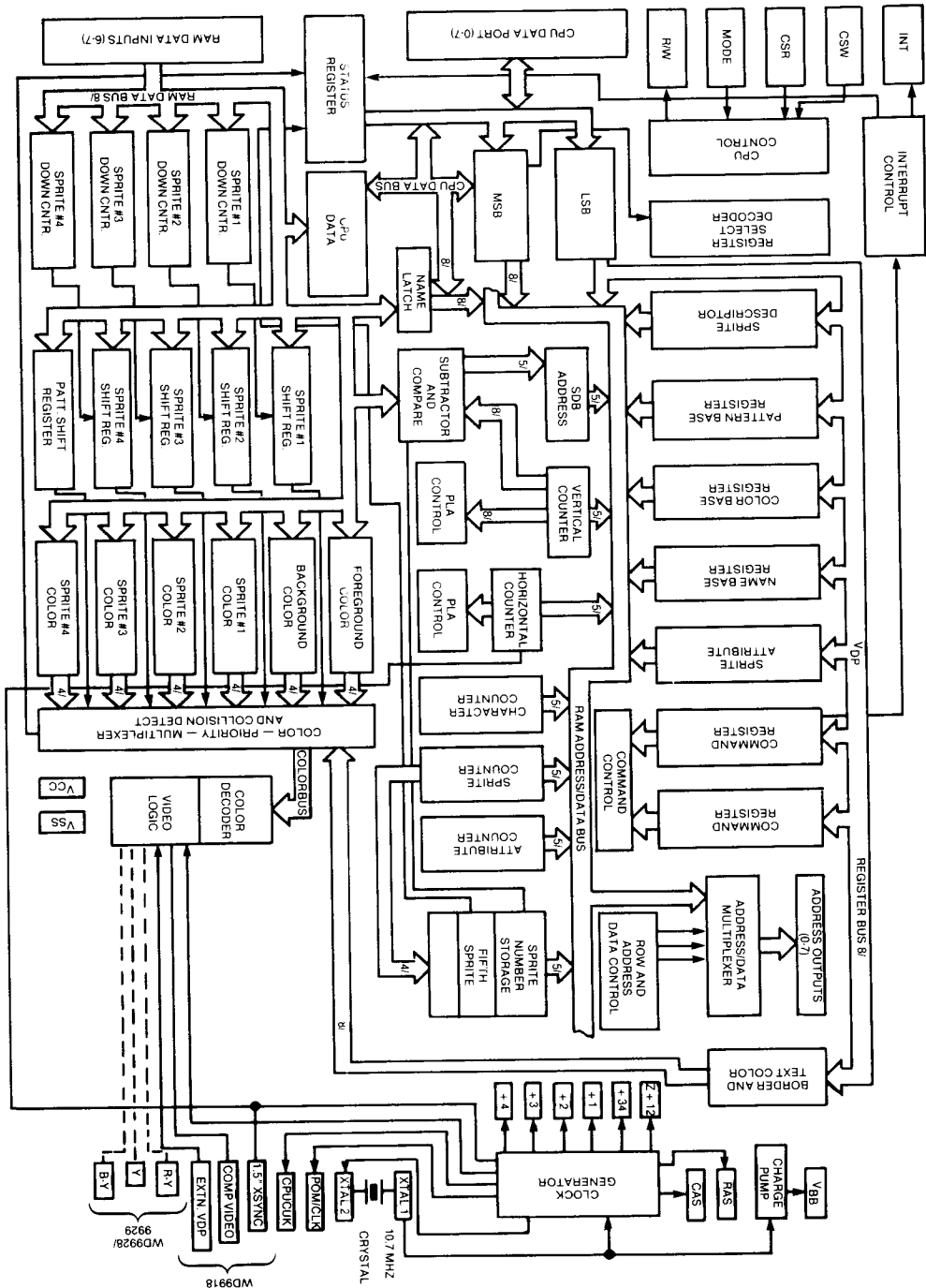

Figure 2. VDP BLOCK DIAGRAM

WD9918/9928/9929

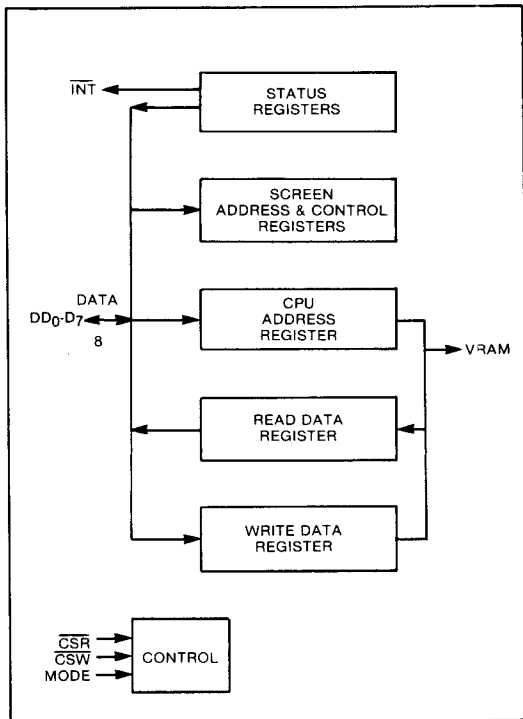

Figure 3. VDP TO CPU INTERFACE

CPU WRITE TO VRAM

The CPU transfers data to the VRAM through the VDP using a 14-bit autoincrementing address register. The address register setup requires 2-byte transfers. A 1-byte transfer is then required to write the data to the addressed VRAM byte. The address register is then autoincremented. Sequential VRAM writes require only 1-byte transfers since the address register is already set up. During setup of the address register, the two MSBs of the second address byte must be 0 and 1 respectively. MODE is high for both address transfers and low for the data transfer. CSW is used in all transfers to strobe the 8 bits into the VDP. See Table 1.

CPU READ FROM VDP STATUS REGISTER

The CPU can read the contents of the status register with a single-byte transfer. MODE is high for the transfer. CSR is used to signal the VDP that a read operation is required.

CPU READ FROM VRAM

The CPU reads from the VRAM through the VDP using the autoincrementing address register. A 1-byte transfer is then required to read the data from the addressed VRAM byte. The address register is then autoincremented. Sequential VRAM data reads require only a 1-byte transfer since the address register is already set up. During setup of the address register, the two MSBs of the second address byte must be 0. By setting up the address this way, a read cycle to VRAM is initiated and read data will be available for the first data transfer to the CPU. (See Table

Table 1. CPU/VDP DATA TRANSFERS

OPERATION	BIT								CSW	CSR	MODE
	0	1	2	3	4	5	6	7			
Write to VDP Register											
Byte 1 Data Write	D0	D1	D2	D3	D4	D5	D6	D7	0	1	1
Byte 2 Register Select	1	0	0	0	0	RS0	RS1	RS2	0	1	1
Write to VRAM											
Byte 1 Address Setup	A6	A7	A8	A9	A10	A11	A12	A13	0	1	1
Byte 2 Address Setup	0	1	A0	A1	A2	A3	A4	A5	0	1	1
Byte 3 Data Write	D0	D1	D2	D3	D4	D5	D6	D7	0	1	0
Read from VDP Register											
Byte 1 Data Read	D0	D1	D2	D3	D4	D5	D6	D7	1	0	1
Read from VRAM											
Byte 1 Address Setup	A6	A7	A8	A9	A10	A11	A12	A13	0	1	1
Byte 2 Address Setup	0	0	A0	A1	A2	A3	A4	A5	0	1	1
Byte 3 Data Read	D0	D1	D2	D3	D4	D5	D6	D7	1	0	0

1). MODE is high for the address byte transfers and low for the data transfers. The VDP requires approximately 8 microseconds to fetch the VRAM byte following the last data transfer and 2 microseconds following address setup.

The CPU interacts with VRAM memory through the VDP. The amount of time necessary for the CPU to transfer a byte of data to or from VRAM memory can vary from 2 to 8 microseconds. Once the VDP has been told to read or write a byte of data to or from VRAM it takes approximately 2 microseconds until the VDP is ready to make the data transfer. In addition to this 2 microsecond delay, the VDP must wait for a CPU access window; i.e., the period of time when the VDP is not occupied with memory refresh or screen display and is available to read or write data.

The worst case time between windows occurs during the Graphics I or Graphics II mode when sprites are being used. During the active display, CPU windows occur once every 16 memory cycles giving a maximum delay of 6 microseconds (a memory cycle takes about 372 nanoseconds). In the Text mode the CPU windows occur at least once out of every three memory cycles or a worst case delay of about 1.1 microseconds. Finally, in the Multicolor mode, CPU windows occur at least once out of every four memory cycles.

If the user needs to access memory in 2 microseconds, two situations occur where the time waiting for an access window is effectively zero. Both of these are independent of the display mode being used.

The first situation occurs when the blank bit of register 1 is 0. With this bit low, the entire screen will show only border color and the VDP does not have to wait for a CPU access window at any time.

The second situation occurs when the VDP is in the vertical refresh mode. The VDP issues an interrupt output at the end of each active area. This signal indicates that the VDP is entering the vertical refresh mode and that for the next 4.3 milliseconds there is no waiting for an access window. If the user wants the CPU to access memory during this interval, it is necessary for the controlling CPU to monitor the interrupt output of the VDP (the CPU can either poll this output or use it as an interrupt input).

The program that monitors the interrupt output must allow for its own delays in responding to the interrupt signal and recognize how much time it has left during the 4300 microsecond refresh period. The CPU must write a 1 to the interrupt enable bit of Register 1 in order to enable the interrupt for each frame, and then read the status register each time an interrupt is issued to clear the interrupt output. A summary of these delay times is presented in Table 2.

Table 2. MEMORY ACCESS DELAY TIMES

CONDITION	MODE	VDP DELAY	TIME WAITING FOR AN ACCESS WINDOW	TOTAL TIME
Active Display Area	Text	2 μ s	0 - 1.1 μ s	2 - 3.1 μ s
Active Display Area	Graphics I, II	2 μ s	0 - 5.95 μ s	2 - 8 μ s
4300 μ s after Vertical Interrupt Signal	All	2 μ s	0 μ s	2 μ s
Register I Blank Bit 0	All	2 μ s	0 μ s	2 μ s
Active Display Area	Multicolor	2 μ s	0 - 1.5 μ s	2 - 3.5 μ s

VDP INTERRUPT

The VDP INT output pin is used to generate an interrupt at the end of each active-display scan, which is about every 1/60 second for the WD9918/9928 and 1/50 second for the WD9929. The INT output is active when the Interrupt Enable bit (IE) in VDP Register 1 is a 1 and the F bit of the status register is a 1. Interrupts are cleared when the status register is read.

VDP INITIALIZATION

The VDP is externally initialized whenever the RESET input is active (low) and must be held low for a minimum of 3 microseconds. The external reset synchronizes all clocks with its falling edge, sets the horizontal and vertical counters to known states, and clears VDP registers 0 and 1. The video display is automatically blanked since the BLANK bit in VDP

register 1 becomes a 0. The VDP, however, continues to refresh the VRAM even though the display is blanked. While the RESET line is active, the VDP does not refresh the VRAM.

VIDEO DISPLAY MODES

The VDP displays an image on the screen that can best be envisioned as a set of display planes sandwiched together. Figure 4 shows the definition of each of the planes. Objects on planes closest to the viewer have higher priority. In cases where two entities on two different planes are occupying the same spot on the screen, the entity on the higher priority plane will show at that point. For an entity on a specific plane to show through, all planes in front of that plane must be transparent at that point. The first 32 planes (Figure 5) each may contain a single sprite.

The areas of the Sprite Planes, outside of the sprite itself, are transparent. Since the coordinates of the sprite are in terms of pixels, the sprite can be positioned and moved about very accurately. Sprites are available in three sizes: 8 x 8 pixels, 16 x 16 pixels, and 32 x 32 pixels.

Behind the Sprite Planes is the Pattern Plane. The Pattern Plane is used for textual and graphics images generated by the Text, Graphics I, Graphics II, or Multicolor modes. Behind the Pattern Plane is the backdrop, which is larger in area than the other planes so that it forms a border around the other planes. The last and lowest priority plane is the Ex-

ternal VDP Plane. Its image is defined by the external VDP input pin which allows the WD9918 to mix the external video signal internal to the chip.

This mixing must occur outside of the chip for the WD9928 and WD9929. This is achieved through the color difference outputs swinging to a special level (sync level is shown in Figure 6) not used by the color difference signals in normal operation. This occurs when bit 7 of Register 0 is set high. External mixing circuitry is required to detect this change in the level of the color difference signals and then switch from the VDP signals to an external source's signals (see Figures 7 and 8).

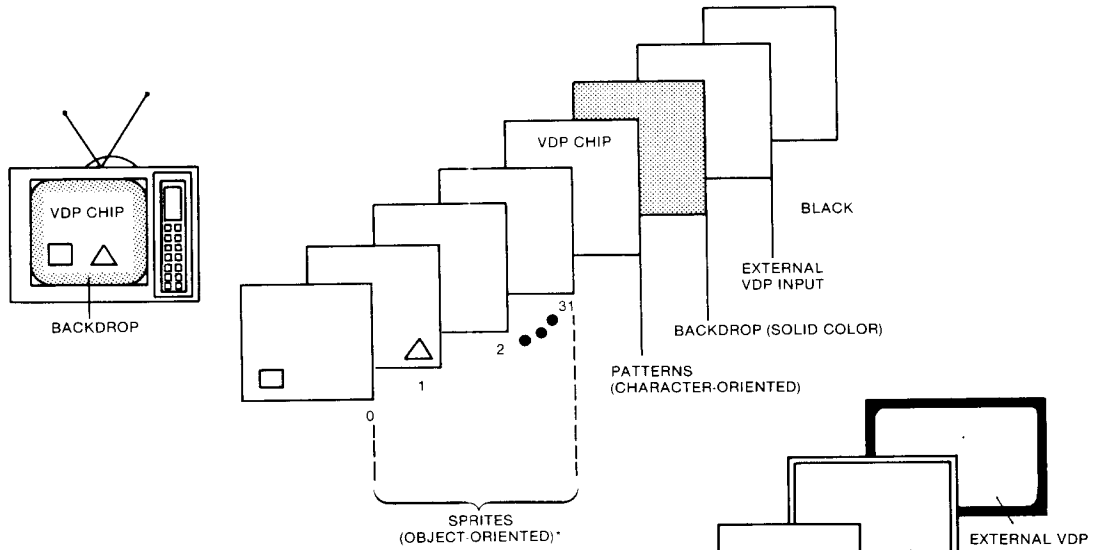

Figure 4. VDP DISPLAY PLANES (DEFINITION)

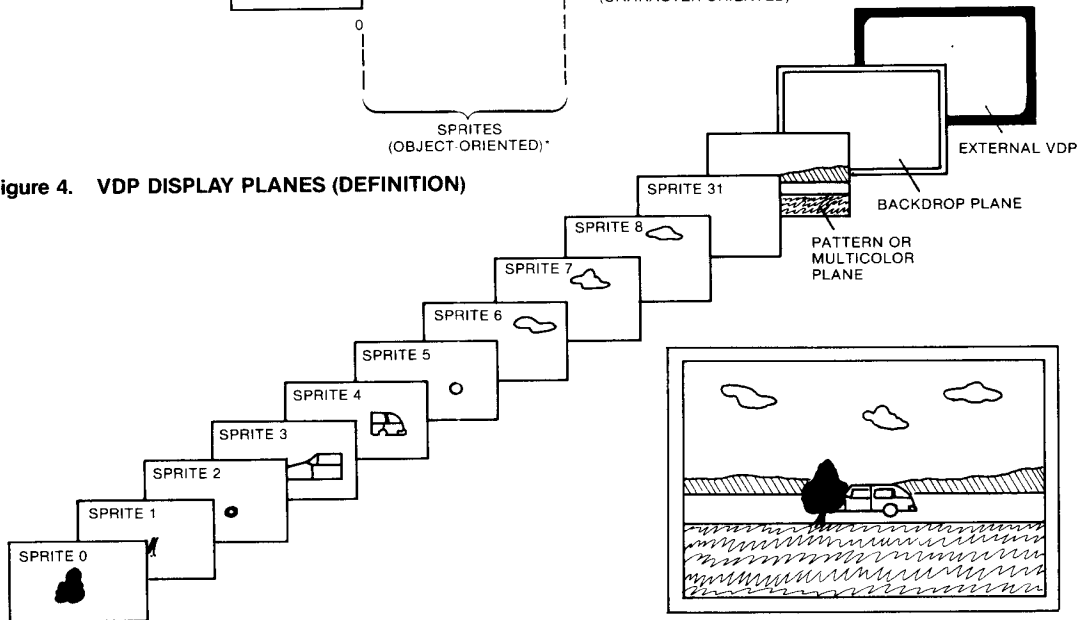

Figure 5. VDP DISPLAY PLANES (FIRST 32 PLANES)

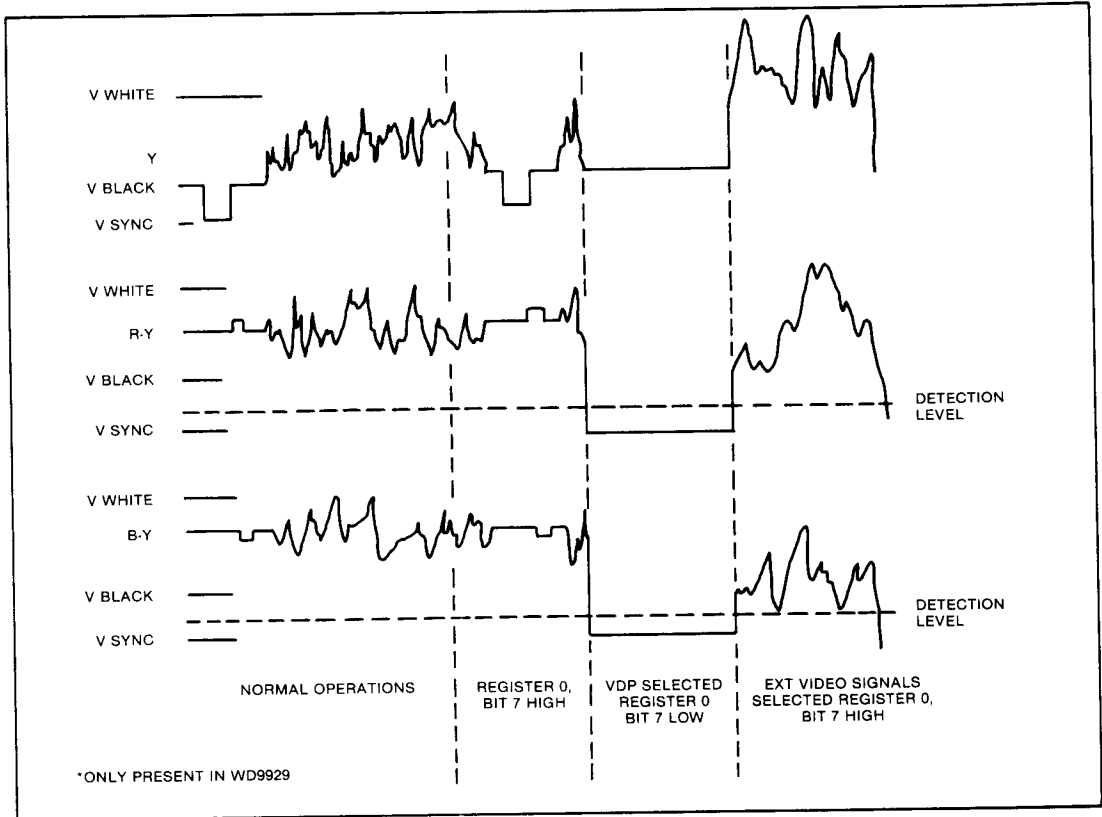

Figure 6. WD9928/9929 SIGNAL WAVEFORMS FOR MULTIPLE VDP OPERATION

The backdrop consists of a single color used for the display borders and as the default color for the active display area. The default color is stored in the VDP Register 7. When the backdrop color register contains the transparent code, the backdrop automatically defaults to black if the external VDP mode is not selected.

The 32 Sprite Planes are used for the 32 sprites in the Multicolor and Graphics modes. They are not used in the Text mode and are automatically transparent. Each of the sprites can cover an 8 x 8, 16 x 16, or 32 x 32 pixel area on its plane. Any part of the plane not covered by the sprite is transparent. All or part of each sprite may also be transparent. Sprite 0 is on the outside or highest plane, and sprite 31 is on the plane immediately adjacent to Pattern Plane. Whenever a pixel in a Sprite Plane is transparent, the color of the next plane can be seen through that plane. If, however, the sprite pixel is non-transparent, the colors of the lower planes are automatically replaced by the sprite color.

There is also a restriction on the number of sprites on

a line. Only four sprites can be active on any horizontal line. Additional sprites on a line will be automatically made transparent for that line. Only those sprites that are active on the display will cause the coincidence flag to set. The VDP status register provides a flag bit and the number of the fifth sprite whenever this occurs. The Pattern Plane is used in the Text, Multicolor, and Graphics modes for display of the graphic patterns of characters. Whenever a pixel on the Pattern Plane is nontransparent, the backdrop color is automatically replaced by the Pattern Plane color. When a pixel in the Pattern Plane is transparent, the backdrop color can be seen through the Pattern Plane.

The VDP has four video color display modes that appear on the Pattern Plane: Graphics I mode, Graphics II mode, Text mode, and Multicolor mode. Graphics I and Graphics II modes cause the Pattern Plane to be broken up into groups of 8 x 8 pixels, called pattern positions. Since the full image is 256 x 192 pixels, there are 32 x 24 pattern positions on the screen in the Graphics modes.

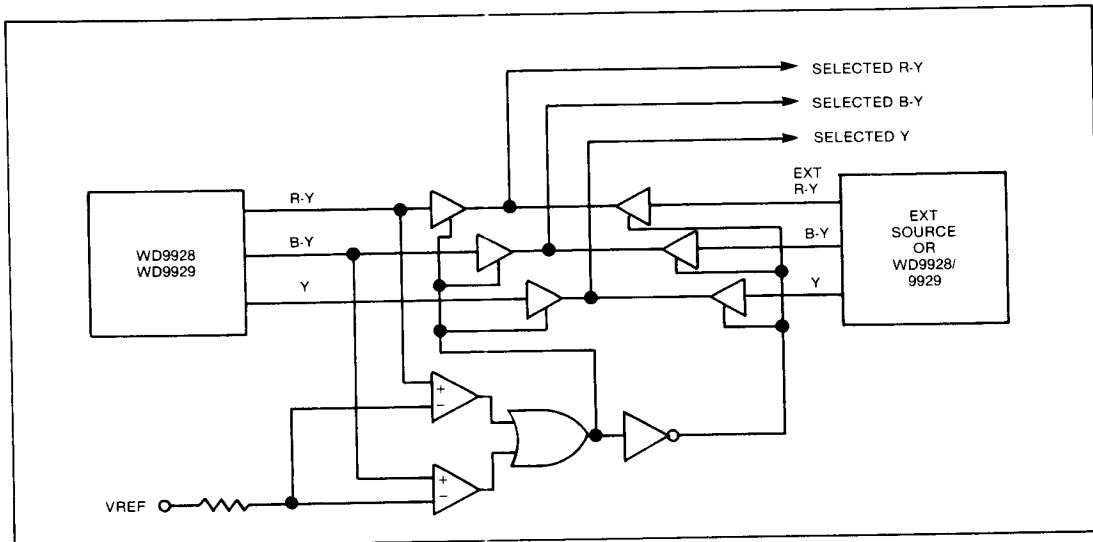

Figure 7.
USING COLOR DIFFERENCE SIGNALS TO MIX EXTERNAL COLOR DIFFERENCE TYPE SOURCE

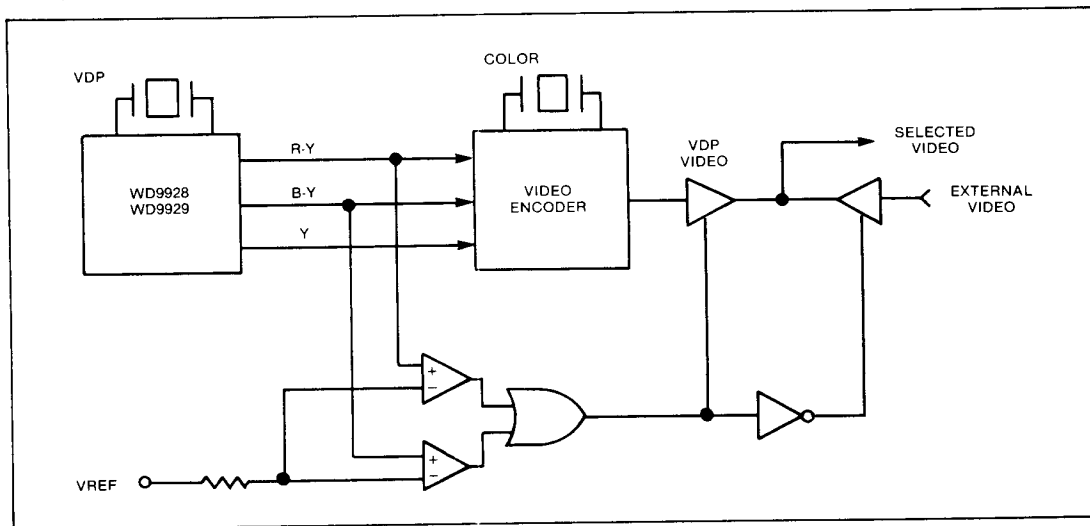

Figure 8. **USING COLOR DIFFERENCE SIGNALS TO MIX EXTERNAL VIDEO SOURCES**

In Graphics I mode, 256 possible patterns may be defined for the 768 pattern positions with two unique colors allowed for each line of a pattern definition. Thus, all 15 colors plus transparent may be used in a single pattern position.

In Text mode, the Pattern Plane is broken into groups of 6 x 8 pixels, called text positions. There are 40 x 24

text positions on the screen in this mode. In Text mode, sprites do not appear on the screen and two colors are defined for the entire screen by VDP Register 7.

In Multicolor mode, the screen is broken into a grid of 64 x 48 positions, each of which is a 4 x 4 pixel. With in each position, one unique color is allowed.

The VDP registers define the base addresses for several sub-blocks within VRAM. These sub-blocks form tables which are used to produce the desired image on the TV screen. The Sprite Pattern Generator Table and the Sprite Attribute Table are used to form sprites. The contents of these tables must all be provided by the microprocessor. Animation is achieved by altering the contents of VRAM in real time.

The VDP can display the 15 colors shown in Table 3. The VDP colors also provide eight different gray levels for displays on monochrome television; the lu-

minance value in the table indicates these levels, 0.00 being black and 1.00 being white. All other values in the table are expressed as percentages of the white/black voltage swing.

NOTE:

The gray levels differ slightly for the WD9918 when compared to the WD9928/9929.

Whenever all planes are of the transparent color at a given point, and external video is not selected, the color shown at that point will be black.

Table 3. COLOR ASSIGNMENTS

COLOR HEX	COLOR	WD9918		WD9928/9929		
		LUMINANCE (DC) VALUE	CHROMINANCE (AC VALUE)	Y	COLOR DIFFERENCE R-Y B-Y	
0	Transparent	0.00	—	—	—	—
1	Black	0.00	—	0.00	.47	.47
2	Medium Green	.53	.53	.53	.07	.20
3	Light Green	.67	.40	.67	.17	.27
4	Dark Blue	.40	.60	.40	.4	1.00
5	Light Blue	.53	.53	.53	.43	.93
6	Dark Red	.47	.47	.47	.83	.30
7	Cyan	.67	.60	.73	0.00	.70
8	Medium Red	.53	.60	.53	.93	.27
9	Light Red	.67	.60	.67	.93	.27
A	Dark Yellow	.73	.47	.73	.57	.07
B	Light Yellow	.80	.33	.80	.57	.17
C	Dark Green	.46	.47	.47	.13	.23
D	Magenta	.53	.40	.53	.73	.67
E	Gray	.80	—	.80	.47	.47
F	White	1.00	—	1.00	.47	.47
—	Black Level	0.00	—	0.00	.47	.47
—	Color Burst	0.00	.40	0.00	47(28) 73(29)	.1(28) .2(29)
—	Sync Level	—0.40	—	— .46	.47	.47
—	External Video	—	—	0.00	.47	.47
—	Level	—	—	0.00	— .46	— .46

GRAPHICS I MODE

The VDP is in Graphics I mode when M1, M2, and M3 bits in VDP registers 1 and 0 are zero. When in this mode the Pattern Plane is divided into a grid of 32 columns by 24 rows of pattern positions as shown in Figure 9. Each of the pattern positions contains 8 x 8 pixel. The tables in VRAM used to generate the Pattern Plane are the Pattern Generator, Name, and

Color Tables which require 2848 VRAM bytes. Figure 10 illustrates the mapping of these tables into the Pattern Plane. Less memory is required if all 256 possible pattern definitions are not required. The tables can be overlapped to reduce the amount of VRAM needed for pattern generation. Examples of VRAM memory allocation are provided in VRAM ADDRESSING EXAMPLE.

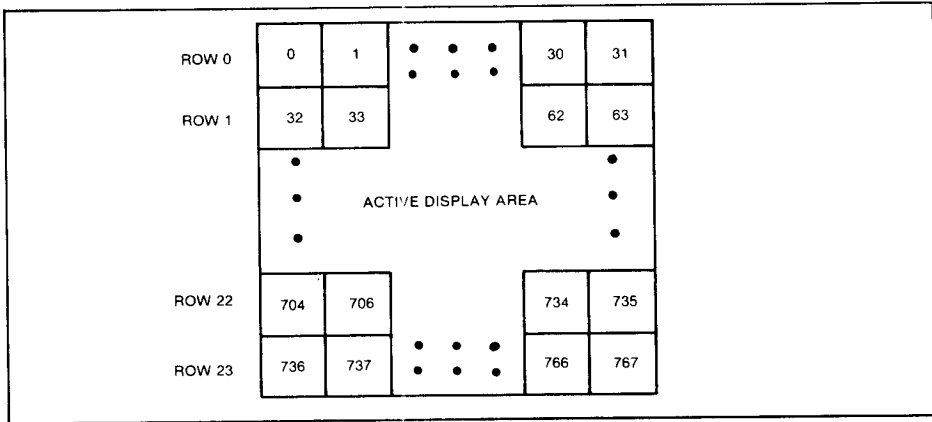

Figure 9. PATTERN GRAPHICS NAME TABLE MAPPING

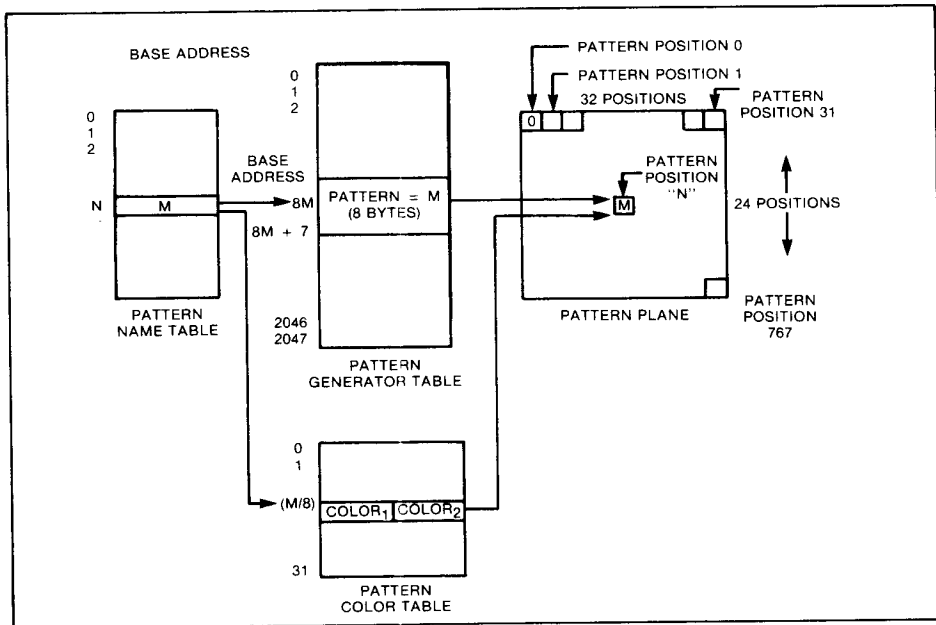

Figure 10. GRAPHICS I MODE MAPPING

The Pattern Generator Table contains a library of patterns that can be displayed in the pattern positions. It is 2048 bytes long and is arranged into 256 patterns, each of which is 8 bytes long, yielding 8 x 8 bits. All of the 1s in the 8-byte pattern can designate one color (color 1), while all the 0s can designate another color (color 0).

The full 8-bit pattern name is used to select one of the 256 pattern definitions in the Pattern Generator

Table. The table is a 2048-byte block in VRAM beginning on a 2-kilobyte boundary. The starting address of the table is determined by the generator base address in VDP Register 4. The base address forms the three MSBs of the 14-bit VRAM address for each Pattern Generator Table entry. The next 8 bits indicate the 8-bit name of the selected pattern definition. The lowest 3 bits of the VRAM address indicate the row number within the pattern definition.

There are 8 bytes required for each of the 256 possible unique 8 x 8 pattern definitions. The first byte defines the first row of the pattern, and the second byte defines the second row. The first bit of each of the eight bytes defines the first column of the pattern. The remaining rows and columns are similarly defined. Each bit entry in the pattern definition selects

one of the two colors for that pattern. A 1 bit selects the color code (color 1) contained in the most significant 4 bits of the corresponding color table byte. A 0 bit selects the other color code (color 0). An example of pattern definition mapping is provided in Figure 11.

ROW/BYTE	COLUMN (PATTERN)						BIT (PATTERN DEFINITION)							
	0	1	2	3	4	5	0	1	2	3	4	5	6	7
0		C	C	C	C	C	0	1	1	1	1	1	0	0
1						C	0	0	0	0	0	1	0	0
2							0	0	0	0	0	1	0	0
3			C	C	C	C	0	0	1	1	1	1	0	0
4						C	0	0	0	0	0	1	0	0
5							0	0	0	0	0	1	0	0
6		C	C	C	C	C	0	1	1	1	1	1	0	0
7							0	0	0	0	0	0	0	0

NOTES:

VDP register 7 entry: 7116.

Color code 7 is cyan (signified above by 'C').

Color code 1 is black (signified above by a space).

Bit 0 is the most significant bit of each data byte.

Figure 11. PATTERN DISPLAY MAPPING

The color of the 1s and 0s is defined by the Pattern Color Table that contains 32 entries, each of which is 1 byte long. Each entry defines two colors: the most significant 4 bits of each entry define the color of the 1s, and the least significant 4 bits define the color of the 0s. The first entry in the color table defines the colors for patterns 0 to 7; the next entry for patterns 8 to 15, and so on. (See Table 4 for assignments.) Thus, 32 different pairs of colors may be displayed simultaneously.

The Pattern Name Table is located in a contiguous 768-byte block in VRAM beginning on a 1-kilobyte boundary. The starting address of the Name Table is determined by the 4-bit Name Table base address field in VDP Register 2. The base address forms the upper 4 bits of the 14-bit VRAM address. The lower 10 bits of the VRAM address are formed from the row and column counters. An example of pattern name table addressing is given in VRAM ADDRESSING EXAMPLE.

Each byte entry in the Name Table is either the name of or the pointer to a pattern definition in the Pattern Generator Table. The upper 5 bits of the 8-bit name identify the color group of the pattern. There are 32 groups of 8 patterns. The same two colors are used for all eight patterns in a group; the color codes are stored in the VDP Color Table. The Color Table is located in a 32-byte block in VRAM beginning on a 64-

Table 4. GRAPHICS I MODE COLOR TABLE

BYTE NO.	PATTERN NO.	BYTE NO.	PATTERN NO.
0	0..7	16	128..135
1	8..15	17	136..143
2	16..23	18	144..151
3	24..31	19	152..159
4	32..39	20	160..167
5	40..47	21	168..175
6	48..55	22	176..183
7	56..63	23	184..191
8	64..71	24	192..199
9	72..79	25	200..207
10	80..87	26	208..215
11	88..95	27	216..223
12	96..103	28	224..231
13	104..111	29	232..239
14	112..119	30	240..247
15	120..127	31	248..255

byte boundary. The table starting address is determined by the 8-bit Color Table base address in VDP Register 3. The base address forms the upper 8 bits

of the 14-bit Color Table entry VRAM address. The next bit is a 0 and the lowest 5 bits are equal to the upper 5 bits of the corresponding Name Table entries.

Since the tables in VRAM have their base addresses defined by the VDP registers, a complete switch of the values in the tables can be made by simply changing the values in the VDP registers. This is especially useful when one wishes to time-slice between two or more screens of graphics.

When the Pattern Generator Table is loaded with a pattern set, manipulation of the Pattern Name Table contents can change the appearance of the screen. Alternatively, a dynamically changing set of patterns throughout the course of a graphics session is easily accomplished since all tables are in VRAM. A total of 2848 VRAM bytes are required for the Pattern, Name, Color and Generator tables. Less memory is needed if all 256 possible pattern definitions are not required; the tables can be overlapped to reduce the amount of VRAM needed for pattern generation. Examples of VRAM memory allocation are provided in VRAM ADDRESSING EXAMPLE.

Graphics II Mode

The VDP is in the Graphics II mode bits (M1 = 0, M2 = 0 and M3 = 1). The Graphics II mode is similar to Graphics I mode except it allows a larger library of patterns so that a unique pattern generator entry may be made for each of the 768 (32 x 24) pattern positions on the video screen. Additionally, more color information is included in each 8 x 8 graphics pattern. Thus, two unique colors may be specified for each byte of the 8 x 8 pattern. A larger amount of VRAM (12 kilobytes) is required to implement the full usage of the Graphics II mode.

Like Graphics I mode, the Graphics II mode Pattern Name Table contains 768 entries which correspond to the 768 pattern positions on the display screen. Because the Graphics I mode pattern names are only 8 bits in length, a maximum of 256 pattern definitions may be addressed using the addressing scheme discussed in VRAM ADDRESSING EXAMPLE. Graphics II mode, however, segments the display screen into three equal parts of 256 pattern positions each and also segments the Pattern Generator Table into three

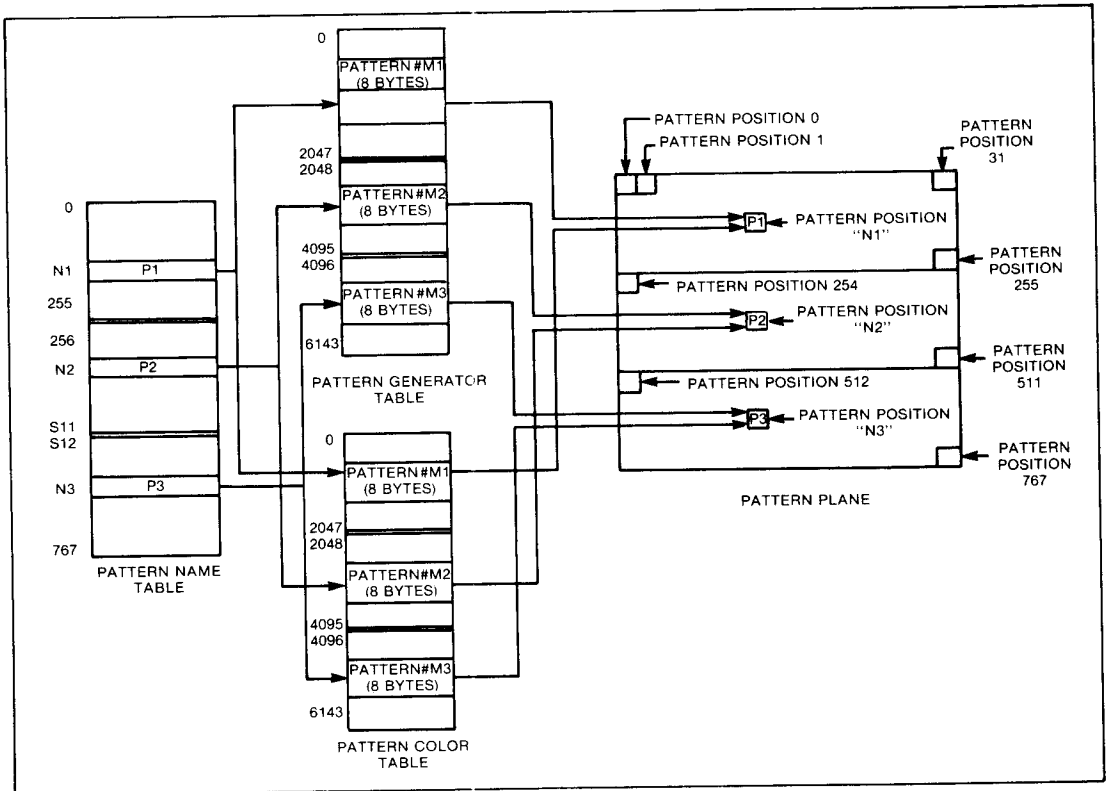

Figure 12. GRAPHICS II MODE MAPPING

equal blocks of 2048 bytes each. Pattern definitions in the first third of the display screen correspond to pattern positions in the upper third. Likewise, pattern definitions in the second and third blocks of the Pattern Generator Table correspond to the second and third areas of the Pattern Plane.

The Pattern Name Table is also segmented into three blocks of 256 names each so that names found in the upper third reference pattern definitions are found in the upper 2048 bytes in Pattern Generator Table. Similarly, the second and third blocks reference pattern definitions in the second 2048-byte block and third-2048 byte block, respectively. Thus, if 768 patterns are uniquely specified, an 8-bit pattern name will be used three times, once in each segment of the Pattern Name Table. The Pattern Generator Table falls on 8-kilobyte boundaries and may be located in the upper or lower half of 16K memory based on the MSB of the pattern generator base in VDP Register 4. The LSBs must be set to all 1s.

The Color Table is also 6144 bytes long and is segmented into three equal blocks of 2048 bytes. Each entry in the Pattern Color Table is 8 bytes which provides the capability to uniquely specify color 1 and color 0 for each of the 8 bytes of the corresponding pattern definition. The addressing scheme is exactly like that of the Pattern Generator Table except for the location of the table in VRAM. This is controlled by the loading of the MSB of the color base in VDP Register 3. The LSBs must be set to all 1s.

Figure 12 illustrates the Graphics II mode mapping scheme. Note that pattern names, P1, P2, and P3, correspond to pattern generator entries in the three blocks of the Pattern Generator Table. Note also how these three names map to the display screen. Figure 13 is an example of a Pattern Generator and Pattern Color Table entry.

	0 1 0 0 0 0 0 1		0 3 4 7	
ROW 0	0 1 0 0 0 0 0 1	B 1 3 B B B B 1	1 (Black)	B (Lt. Yellow)
1	0 0 1 0 0 0 1 0	B B 7 B B B 7 B	7 (Cyan)	B (Lt. Yellow)
2	0 0 0 1 0 1 0 0	B B B C B C B B	C (Green)	B (Lt. Yellow)
3	0 0 0 0 1 0 0 0	B B B B E B B B	E (Gray)	B (Lt. Yellow)
4	0 0 0 0 1 0 0 0	B B B B 8 B B B	8 (Med. Red)	B (Lt. Yellow)
5	0 0 0 0 1 0 0 0	B B B B 5 B B B	5 (Lt. Blue)	B (Lt. Yellow)
6	0 0 0 0 1 0 0 0	B B B B 6 B B B	6 (Dk. Red)	B (Lt. Yellow)
7	0 0 0 0 1 0 0 0	B B B D B B B	D (Magenta)	B (Lt. Yellow)
	PATTERN GENERATOR TABLE ENTRY	PATTERN	PATTERN COLOR TABLE ENTRY	

Figure 13. PATTERN DISPLAY MAPPING

Multicolor Mode

The VDP is in Multicolor mode when mode bits M1 = 0, M2 = 1, and M3 = 0. Multicolor mode provides an unrestricted 64 x 48 color square display. Each color square contains a 4 x 4 block of pixels. The color of each of the color squares can be any one of the 15 video display colors plus transparent. Consequently, all 15 colors can be used simultaneously in the Multicolor mode. The Backdrop and Sprite Planes are still active in the Multicolor mode.

The Multicolor Name Table is the same as that for the graphics modes, consisting of 768 name entries, although the name no longer points to a color list.

Color is now derived from the Pattern Generator Table. The name points to an 8-byte segment of VRAM in the Pattern Generator Table.

Only 2 bytes of the 8-byte segment are used to specify the screen image. These 2 bytes specify four colors, each color occupying a 4 x 4-pixel area. The 4 MSBs of the first byte define the color of the upper left quarter of the multicolor pattern; the LSBs define the color of the upper right quarter. The second byte similarly defines the lower left and right quarters of the multicolor pattern. The 2 bytes thus map into an 8 x 8-pixel multicolor pattern. (See Figure 14).

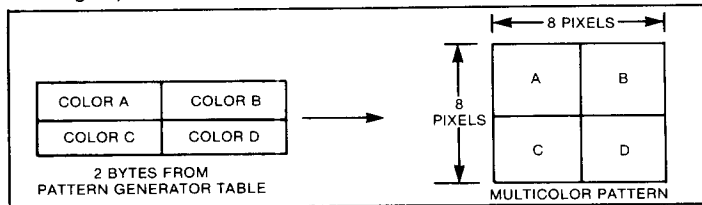

Figure 14. MULTICOLOR LIST MAPPING

The location of the 2 bytes within the 8-byte segment pointed to by the name is dependent upon the screen position where the name is mapped. For names in the top row (names 0-31), the 2 bytes are the first two within the groups of 8-byte segments pointed to by the names. The next row of names (32-63) uses the bytes 3 and 4 within the 8-byte segments. The next row of names uses bytes 5 and 6 while the last row of names uses bytes 7 and 8. This series repeats for the remainder of the screen.

For example, referring to Figure 15 if Name Table entry 0 (pattern position 0) multicolor block #N (name = N), the multicolor pattern displayed will be an 8 x

8-pixel block consisting of colors A, B, C, and D which comprise the first two bytes of the Multicolor Table. If, however, name #N is located in Name Table entry 33, (Pattern position 33), the colors displayed will be colors E, F, G, and H as specified by bytes 3 and 4 of the multicolor block pointed to by the name.

Likewise, pattern positions which lie in rows 2 and 3 would cause colors, I, J, K, L and colors M, N, O, P, respectively, to be displayed. Thus, it can be seen that the color displayed from the multicolor generator block is dependent upon pattern position on the screen. Figure 16 illustrates the Multicolor mode mapping scheme.

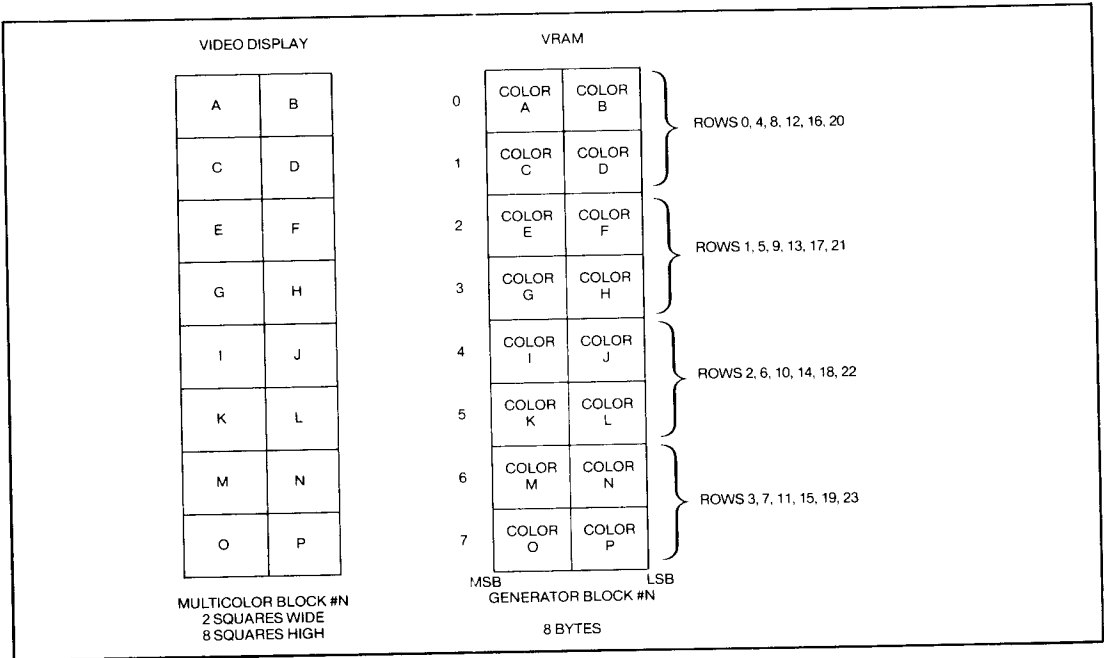

Figure 15. MULTICOLOR BLOCK DISPLAY

The mapping of VRAM contents to screen image is simplified by using duplicate names in the Name Table since the series of bytes used within the 8-byte segment specifies a 2 x 8 color square pattern on the screen as a straightforward translation from the 8-byte segment in VRAM pointed to by the common name.

When used in this manner, 768 bytes are still used for the Name Table and 1536 bytes are used for the color information in the Pattern Generator Table (24 rows x 32 columns x 8 bytes/pattern position). Thus, a total of 1728 bytes in VRAM are required. It should be noted that the tables begin on even 1K and 2K boundaries and are therefore not contiguous. An example of multicolor VRAM memory allocation is given in VRAM ADDRESSING EXAMPLE.

Text Mode

The VDP is in Text mode when mode bits M1 = 1, M2 = 0, and M3 = 0. In this mode, the screen is divided into a grid of 40 text positions across and 24 down. (See Figure 17). Each of the text positions contains 6 pixels across and 8 pixels down. The tables used to generate the Pattern Plane are the Pattern Name Table and the Pattern Generator Table. There can be up to 256 unique patterns defined at any time. The pattern definitions are stored in the Pattern Generator Table in VRAM and can be dynamically changed. The VRAM contains a Pattern Name Table which maps the pattern definition into each of the 960 pattern cells on the Pattern Plane (Figure 18). Sprites are not available in Text mode.

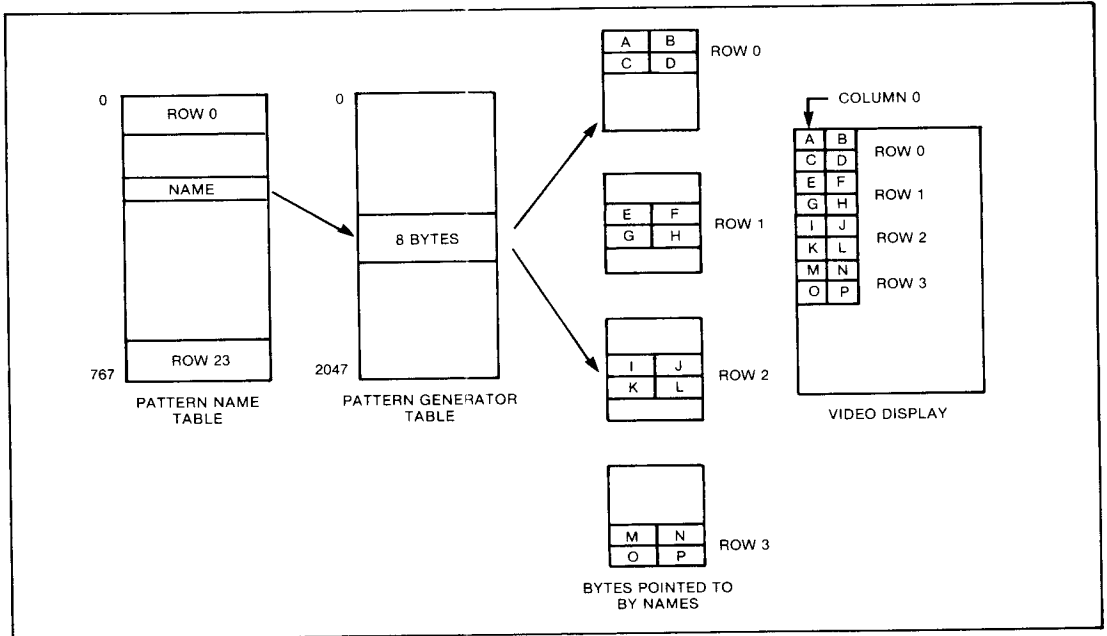

Figure 16. MULTICOLOR MODE MAPPING

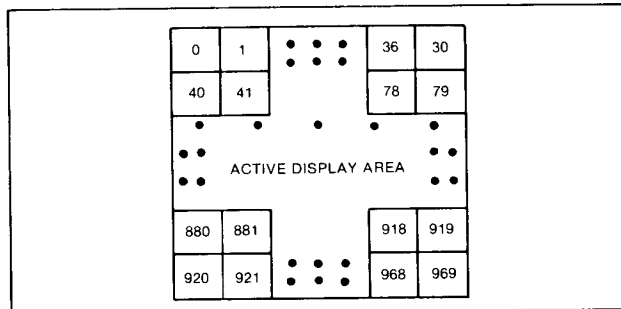

Figure 17. TEXT MODE NAME TABLE PATTERN POSITIONS

As with the Graphics modes, the Pattern Generator Table contains a library of text patterns that can be displayed in the text positions. It is 2048 bytes long and is arranged in 256 text patterns, each of which is 8 bytes long. Since each text position on the screen is only 6 pixels across, the least significant 2 bits of each text pattern are ignored, yielding 6 x 8 bits in each text pattern. Each 8-byte block defines a text pattern in which all the 1s in the text pattern take on one color when displayed on the screen, while all the 0s take on another color. These colors are chosen by loading VDP Register 7 with the color 1 and color 0 in the left and right nibbles, respectively WRITE ONLY

REGISTERS.

In the Text mode, the Pattern Name Table determines the position of the text pattern on the screen as shown in Figure 18. There are 960 entries in the Pattern Name Table, each 1 byte long. There is a one-to-one correspondence between text pattern positions on the screen and entries in the Pattern Name Table (40 x 24 = 960). The first 40 entries correspond to the top row of text pattern positions on the screen, the next 40 to the second row, and so on. The value of an entry in the Pattern Name Table indicates which of the 256 text patterns is to be placed at that spot on the Pattern plane.

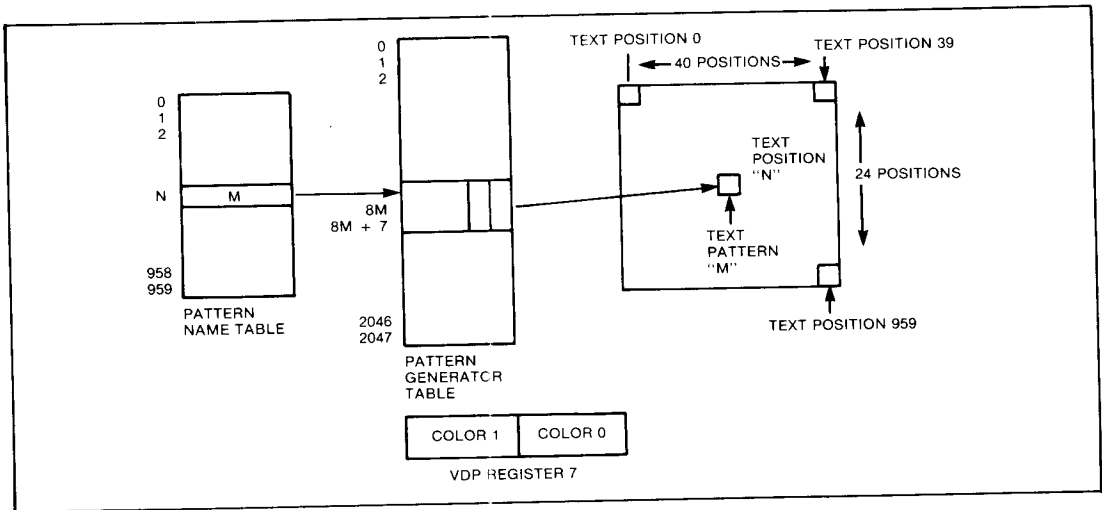

Figure 18. MAPPING OF VRAM INTO THE PATTERN PLANE IN TEXT MODE

The Pattern Name Table is located in a contiguous 960-byte block in VRAM, beginning on a 1-kilobyte boundary. The starting address of the name table is determined by the 4-bit name table base address field in VDP Register 2. The base address forms the upper 4 bits of the 14-bit VRAM address. The lower 10 bits of the VRAM address point to 1 of 960 pattern cells. The name table is organized by rows.

Each byte entry in the name table is the pointer to a pattern definition in the Pattern Generator Table. The same two colors are used for all 256 patterns; the color codes are stored in VDP Register 7.

As the name implies, the Text mode is intended mainly for textual applications, especially those in which the 32 patterns-per-line in Graphics modes is insufficient. The advantage is that eight more patterns can be fitted onto one line; the disadvantages are that sprites cannot be used, and only two colors are available for the entire screen.

With care, the same text pattern set that is used in Text mode can be also used in Graphics I mode. This is done by ensuring that the least significant 2 bits of all the character patterns are 0. Thus, a switch from Text mode to Pattern mode results in a stretching of the space between characters, and a reduction of the number of characters per line from 40 to 32. As with the Graphics Modes, once a character set has been defined and placed into the Pattern Generator, updating the Pattern Name Table will produce and manipulate textual material on the screen.

The full 8-bit pattern name is used to select 1 of the 256 pattern definitions in the pattern generator table. The table is a 2048-byte block in VRAM, beginning on a 2-kilobyte boundary. The starting address of the table is determined by the generator base address in

VDP Register 4. The base address forms the 3 MSBs of the 14-bit VRAM address for each Pattern Generator Table entry. The next 8 bits are equal to the 8-bit name of the selected pattern definition. The lowest 3 bits of the VRAM address are equal to the row number within the pattern definition.

There are 8 bytes required for each of the 256 possible unique 6 x 8 pattern definitions. The first byte defines the first row of the pattern, and the second byte defines the second row. The least significant 2 bits in each byte are not used. However, it is strongly recommended that these bits be 0s. Each bit entry in the pattern definition selects one of the two colors for that pattern. A 1 bit selects the color code (color 1) contained in the most significant 4 bits of VDP Register 7. A 0 bit selects the other color code (color 0) which is in the least significant 4 bits of the same VDP Register. Figure 18 is an example of pattern mapping.

A total of 3008 VRAM bytes are required for the Pattern Name Generator Tables. Less memory is required if all 256 possible pattern definitions are not required; the tables can be overlapped to reduce the amount of VRAM needed for pattern generation. Examples of VRAM memory allocation are provided in VRAM ADDRESSING EXAMPLE.

Sprites

The video display can have up to 32 sprites on the highest priority video planes. The sprites are special animation patterns which provide smooth motion and multilevel pattern overlaying. The location of a sprite is defined by the top left-hand corner of the sprite pattern. The sprite can be easily moved pixel-by-pixel by redefining the sprite origin. This provides

a simple but powerful method of quickly and smoothly moving special patterns. The sprites are not active in the Text mode. The 32 Sprite Planes are fully transparent outside of the sprite itself.

The sub-blocks in VRAM that define sprites are the Sprite Attribute Table (see Figure 19) and the Sprite

Generator Table. These tables are similar to their equivalents in the pattern realm in that the Sprite Attribute Table specifies where the sprite goes on the screen, while the Sprite Generator Table describes what the sprite looks like. Sprite Pattern formats are given in Table 5.

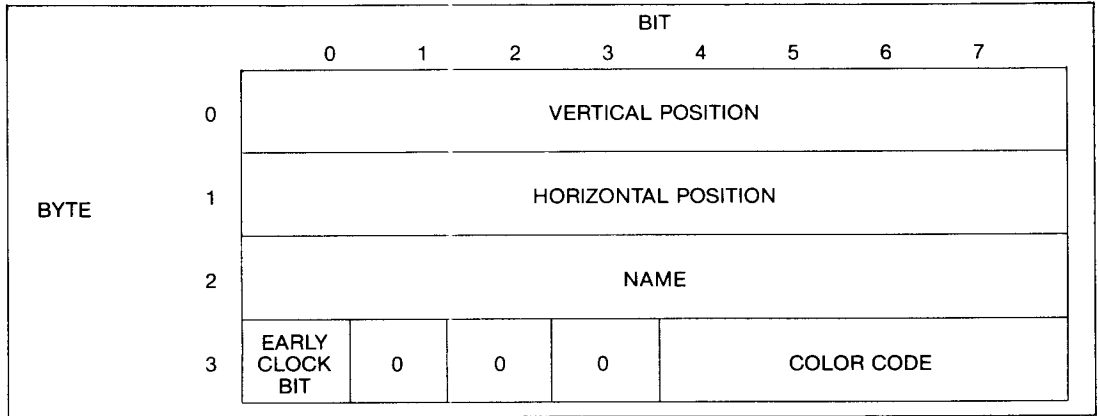

Figure 19. SPRITE ATTRIBUTE TABLE ENTRY

Table 5. SPRITE PATTERN FORMATS

SIZE	MAG	AREA	RESOLUTION	BYTES/PATTERN
0	0	8 x 8	single pixel	8
1	0	16 x 16	single pixel	32
0	1	16 x 16	2 x 2 pixels	8
1	1	32 x 32	2 x 2 pixels	32

Figure 20 illustrates the manner in which the VRAM tables map into the existence of sprites on the display. Since there are 32 sprites available for display, there are 32 entries in the Sprite Attribute Table. Each entry consists of four bytes. The entries are ordered so that the first entry corresponds to the sprite on the sprite 0 plane, the next to the sprite on the sprite 1 plane, and so on. The Sprite Attribute Table is 4 x 32 = 128 and is located in a contiguous 128-byte block in VRAM, beginning on a 128-byte boundary.

The starting address of the table is determined by the 7-bit Sprite Attribute Table base address in VDP Register 5. The base address forms the upper 7 bits of the 14-bit VRAM address. The next 5 bits of the VRAM address are equal to the sprite number. The lowest 2 bits select 1 of the 4 bytes in Sprite 2 Attribute Table entry for each sprite. Each table entry contains 4 bytes which specify the sprite position, sprite pattern name, and color, as shown in Figure 19.

The first two bytes of each entry of the Sprite Attribute Table determine the position of the sprite on the display. The first byte indicates the vertical distance

of the sprite from the top of the screen, in pixels. It is defined such that a value of -1 puts the sprite butted up at the top of the screen, touching the backdrop area. The second byte describes the horizontal displacement of the sprite from the left edge of the display. A value of 0 butts the sprite up against the left edge of the backdrop. Note that all measurements are taken from the upper left pixel of the sprite.

When the first two bytes of an entry position a sprite so it overlaps backdrop, the part of the sprite that is within the backdrop is displayed normally. The part of the sprite that overlaps the backdrop is hidden from view by the backdrop. This allows the animator to move a sprite into display from behind the backdrop.

The displacement in the first byte is partially signed, in that values for vertical displacement between -31 and 0 (E116 to 0) allow a sprite to bleed-in from the top edge of the backdrop. Similarly, horizontal displacement values in the vicinity of 255 allow a sprite to bleed-in from the right side of the side of the screen. To allow sprites to bleed-in from the left edge

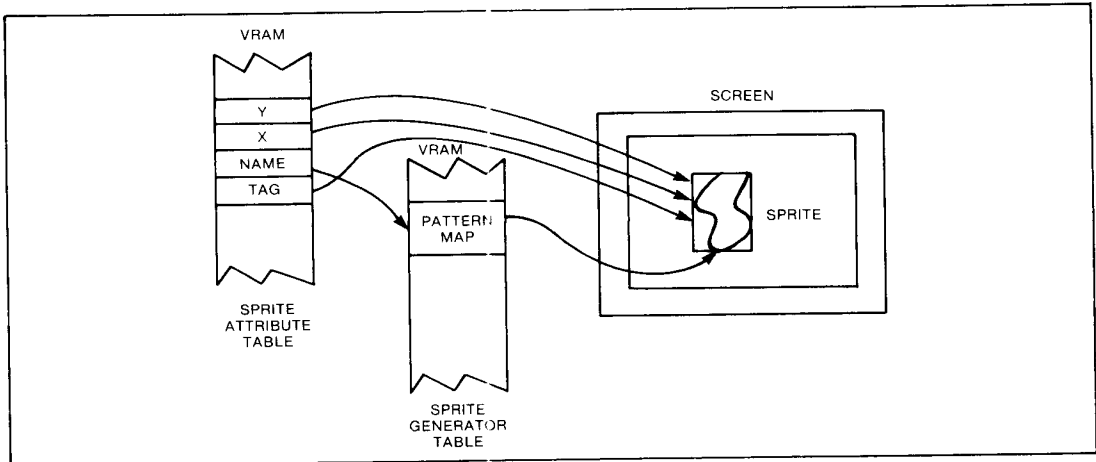

Figure 20. SPRITE MAPPING

of the backdrop, a special bit in the third byte of the Sprite Attribute Table entry is used.

Byte 3 of the Sprite Attribute Table entry contains the pointer to the Sprite Generator Table that specifies what the sprite should look like. This is an 8-bit pointer to the sprite patterns definition, the Sprite Generator Table. The sprite name is similar to that in the Graphics Modes.

Byte 4 of the Sprite Attribute Table entry contains the color of the sprite in its lower 4 bits (see Table 3 for color assignments). The MSB is the Early Clock (EC) bit. When set to 0, this bit does nothing. When set to 1, the horizontal position of the sprite is shifted to the left by 32 pixels. This allows a sprite to bleed-in from the left edge of the backdrop. Values for horizontal displacement (byte 2 in the entry) in the range 0 to 32 cause the sprite to overlap with the left-hand border of the backdrop.

The Sprite Generator Table is a maximum of 2048 bytes long beginning on the 2-kilobyte boundaries. It is arranged into 256 blocks of 8 bytes each. The third byte of the Sprite Attribute Table entry, then specifies which 8-byte block to use to specify a sprite's shape. The 1s in the Sprite Generator cause the sprite to be defined at the point; 0s cause the transparent color to be used. The starting address of the table is determined by the sprite generator base address in VDP Register 6. The base address forms the 3 MSB of the 14-bit VRAM address. The next 8 bits of the address are equal to sprite name, and the last 3 bits are equal to the row number within the sprite pattern. The address formation is slightly modified for SIZE=1 sprites.

There is a maximum limit of four sprites that can be displayed on one horizontal line. If this rule is violated, the four highest-priority sprites on the line are displayed normally. The fifth and subsequent sprites

are not displayed on that line. Furthermore, the fifth-sprite bit in the VDP status register is set to a 1, and the number of the violating fifth sprite is loaded into the status register STATUS REGISTER.

Larger sprites than 8 x 8 pixels can be used if desired. The MAG and SIZE bits in VDP register 1 are used to select the various options described in the following paragraphs.

MAG = 0, SIZE = 0: No options chosen

MAG = 1, SIZE = 0: The Sprite Generator Table uses 8 bytes to describe the sprite; however, each bit in the Sprite Generator maps into 2 x 2 pixels on the TV screen, effectively doubling the size of the sprite to 16 x 16.

MAG = 0, SIZE = 1: The Sprite Generator Table uses 31 bytes to define the sprite shape; the result is a 16 x 16-pixel sprite. The mapping of the 32 bytes into the sprite image is as shown in Figure 21. Mapping is still 1 bit to 1 pixel.

MAG = 1, SIZE = 1: Same as MAG = 0, SIZE = 1 except each bit now maps into a 2-pixel area, yielding a 32 x 32 sprite.

The VDP provides sprite coincidence checking. The coincidence status flag in the VDP status register is set to a 1 whenever two active sprites have 1 bits at the same screen location.

Sprite processing is terminated if the VDP finds a value of 208 (D016) in the vertical position field of any entry in the Sprite Attribute Table. This permits the Sprite Attribute Table to be shortened to the minimum size required; it also permits the user to blank out part or all of the sprites by simply changing one byte in VRAM.

A total of 2176 VRAM bytes are required for the Sprite Name and Pattern Generator Tables. Significantly less memory is required if all 256 possible sprite pattern definitions are not required. The Sprite Attribute Table can also be shortened as described in the preceding paragraph. The tables can be overlapped to reduce the amount of VRAM required for sprite generation. Examples of VRAM memory allocation are provided in VRAM ADDRESSING EXAMPLE.

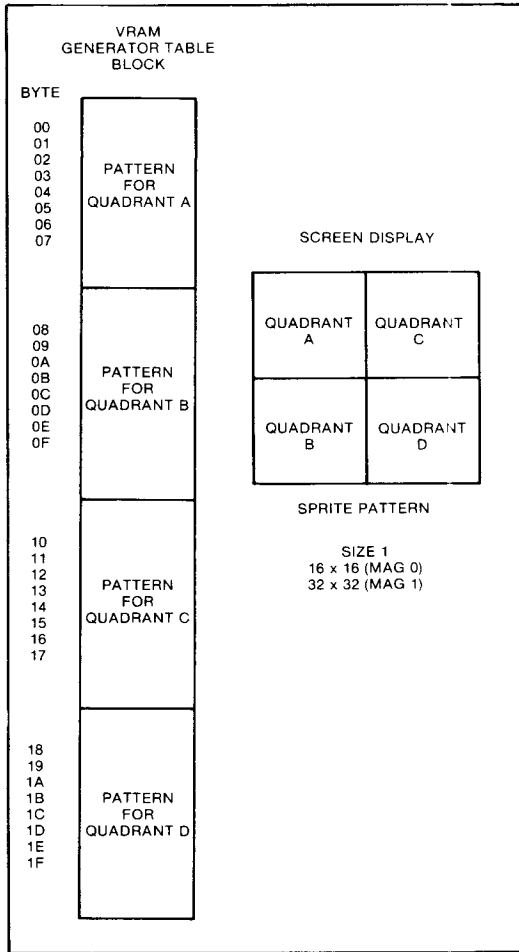

Figure 21. SIZE 1 SPRITE MAPPING

A Step-by-Step Approach to Create Patterns and Sprites

PATTERNS:

1. Use an 8 x 8 pattern similar to that in Figure A. Each small square represents one pixel on the screen.

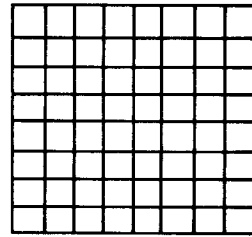

Figure A.

2. Fill in the blocks to create your text character or graphics pattern. Examples of the letter A and an ARROW are shown in Figures B and C.

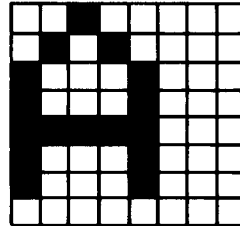

Figure B.

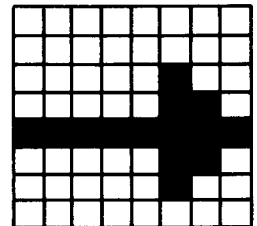

Figure C.

NOTE:

If these patterns are to be used in the Text mode, (40 patterns per line), the pattern should be inside a left-justified 6 x 8 block like the A shown in Figure B. If all of the Text patterns are inside this 6 x 8 block, they can be used for Text and Graphics 1 and 2 modes.

3. Assign 1s to the filled-in areas and 0s to the blanks. Then convert the 1s and 0s to their hexadecimal equivalents, as shown in Figure D.

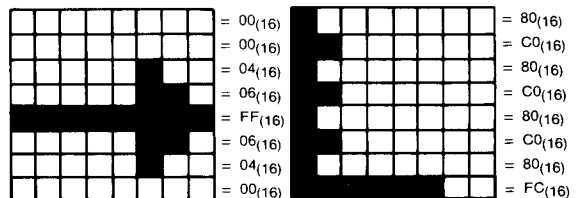
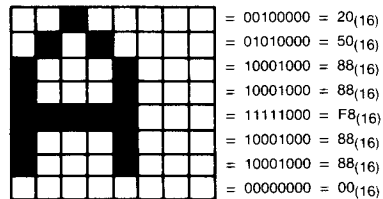
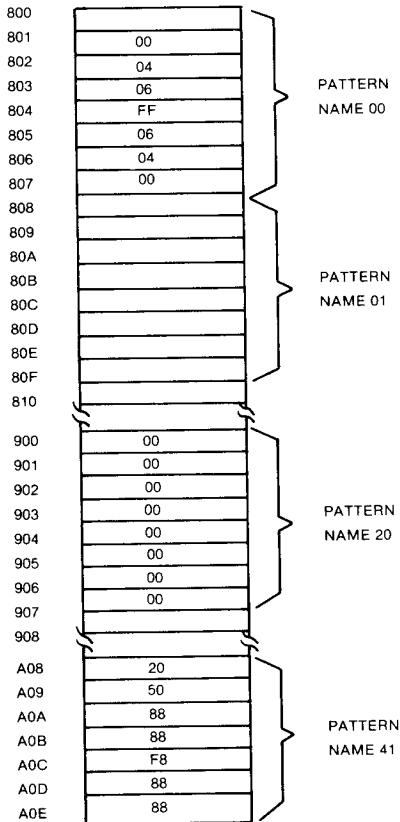

Figure D.

- Now place the eight bytes defining the pattern into the Pattern Generator Table. Assume the Pattern Generator Table. Assume the Pattern Generator Table sub-block is located at 800_{16} and the arrow pattern is to be named 00_{16} . Then place the eight pattern bytes as follows:



SPRITES

- Determine whether to use 8×8 or 16×16 sprite patterns. Then use the appropriate work pattern, as shown in Figures E and F.

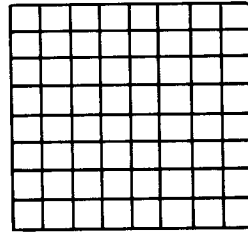

Figure E.

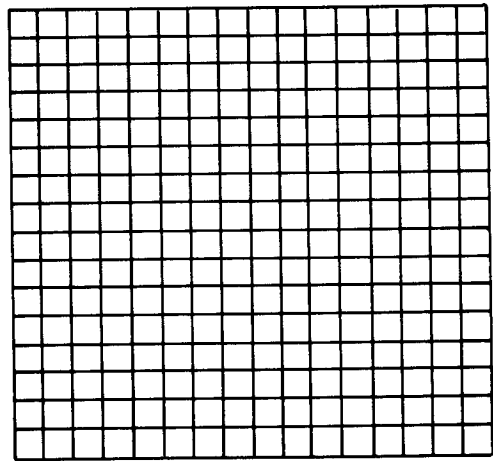

Figure F.

- Fill in the blocks to create your sprite pattern. Examples are shown in Figures G and H.

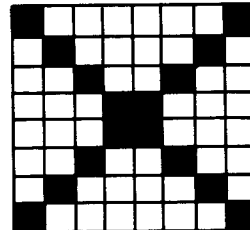

Figure G.

NOTE:

When using text in your applications, you can place the eight bytes of the text character in its ASCII number location.

Example: ASCII SPACE = 20_{16}

- ? = $3F_{16}$
- A = 41_{16}
- B = 42_{16}
- C = 43_{16}
- Etc.

This simplifies writing text to the screen. Simply write the ASCII name directly to the Pattern Name Table. A space character is shown in Pattern Generator Table position 20, and A is shown in pattern name 41.

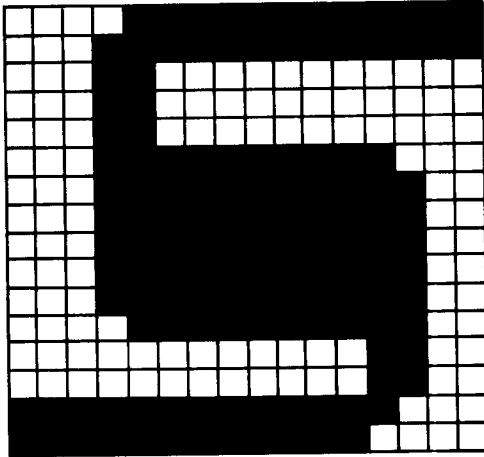

Figure H.

3. Next encode the sprite patterns as in the Pattern Section. The 8 x 8 sprite encodes exactly as the 8 x 8 pattern, but the 16 x 16 sprite encodes as shown in Figure J.

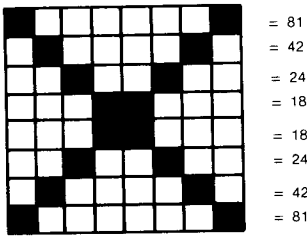

Figure I.

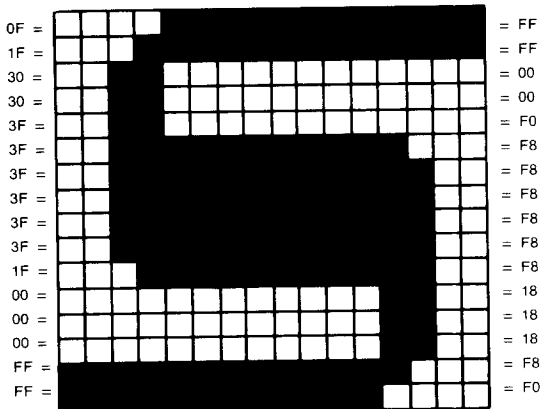

Figure J.

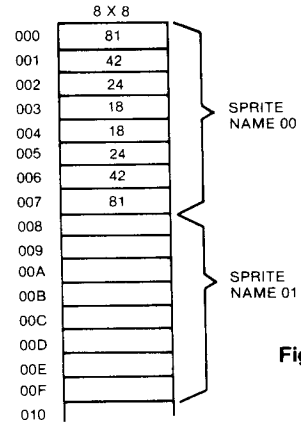

Figure K.

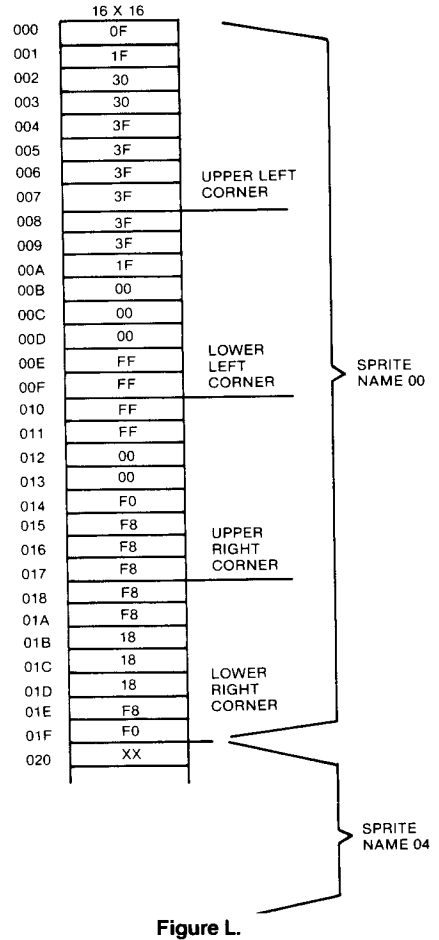

Figure L.

Break the 16 x 16 block pattern into four 8 x 8 patterns. Next, encode the 8 x 8 patterns starting in the upper left corner, then do the lower left, upper right, and lower right.

- Place the 8 bytes for 8 x 8 sprites or 32 bytes for 16 x 16 sprites in the Sprite Generator Table. Assuming the sprite generator table is located at location 0000, Figures K and L show how the tables should look for 8 x 8 and 16 x 16 sprites.

16 x 16 sprite patterns start in the table with the byte from the upper left-hand corner. Then start with the upper right, going toward the lower right.

M1	M2	M3	
0	0	0	Graphics I mode
0	0	1	Graphics II mode
0	1	0	Multicolor Mode
1	0	0	Text mode

- BIT 5 Reserved
- BIT 6 Size (sprite size select)
 - 0 selects Size 0 sprites (8 x 8 bit)
 - 1 selects Size 1 sprites (16 x 16 bits)
- BIT 7 MAG (Magnification option for sprites)
 - 0 selects MAG0 sprites (1X)
 - 1 selects MAG1 sprites (2X)

WRITE-ONLY REGISTERS

The eight VDP write-only registers are shown in Figure 22. They are loaded by the CPU as described in CPU Write to VDP Register. Registers 0 and 1 contain flags to enable or disable various VDP features and modes. Registers 2 through 6 contain values that specify starting locations of various sub-blocks of VRAM. The definitions of these sub-blocks are described in VIDEO DISPLAY MODE. Register 7 is used to define backdrop and text colors.

Each register is described in the following paragraphs.

Register 0

Register 0 contains two VDP option control bits. All other bits are reserved for future use and must be 0s.

- BIT 6 M3 (mode bit 3) (see Coincidence Flag (C) for table and description)
- BIT 7 External VDP enable/disable
 - 0 disables external VDP input
 - 1 enables external VDP input

NOTE:

Enabling bit 7 in the WD9928/9929 causes A-Y and B-Y to go the sync level only when all planes in front of the pixel under question are transparent.

Register 1 (contains 8 VDP option control bits)

- BIT 0 4/16K selection
 - 0 selects 4027 RAM operation
 - 1 selects 4108/4116 RAM operation
- BIT 1 BLANK enable/disable
 - 0 causes the active display area to blank
 - 1 enables the active display
 - Blanking causes the display to show border color only
- BIT 2 IE (Interrupt Enable)
 - 0 disables VDP interrupt
 - 1 enables VDP interrupt
- BIT 3,4 M1, M2 (mode bits 1 and 2)
M1, M2 and M3 determine the operating mode of the VDP:

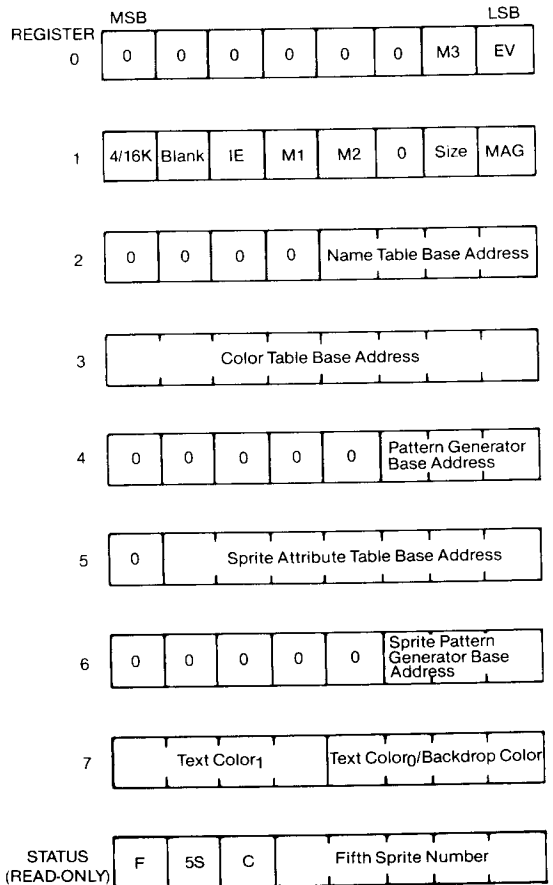

Figure 22. VDP REGISTERS

Register 2

Register 2 defines the base address of the Name Table sub-block. The range of its contents is from 0 to 15. The contents of the register form the upper 4 bits of the 14-bit Name Table addresses; thus the Name Table base address is equal to (Register 2) * 400(hex).

Register 3

Register 3 defines the base address of the Color Table sub-block. The range of its contents is from 0 to 255. The contents of the register form the upper 8 bits of the 14-bit Color Table addresses; thus the Color Table base address is equal to (Register 3) * 40(hex).

Register 4

Register 4 defines the base address of the Pattern, Text or Multicolor Generator sub-block. The range of its contents is 0 through 7. The contents of the register form the upper 3 bits of the 14-bit Generator addresses; thus the Generator base address is equal to (Register 4) * 800(hex).

Register 5

Register 5 defines the base address of the Sprite Attribute Table sub-block. The range of its contents is from 0 through 127. The contents of the register form the upper 7 bits of the 14-bit Sprite Attribute Table addresses; thus the base address is equal to (Register 5) * 80(hex).

Register 6

Register 6 defines the base address of the Sprite Pattern Generator sub-block. The range of its contents is 0 through 7. The contents of the register form the upper 3 bits of the 14-bit Sprite Pattern Generator addresses; thus the Sprite Pattern Generator base address is equal to (Register 6) * 800(hex).

Register 7

The upper 4 bits of Register 7 contain the color code of color 1 in the Text mode. The lower 4 bits contain the color code for color 0 in the Text mode and the backdrop color in all modes.

Setup Values for VDP Registers 2 through 6.

VRAM TABLE ADDRESSING

Register 2 in the VDP contains the starting address for the Name Table sub-block.

$R2 * 400(16) = \text{START ADDRESS}$

R2 ADDRESS	
00	0000
01	0400
02	0800
03	0C00 — Maximum Number for 4K RAMs
04	1000
05	1400
06	1800
07	1C00
08	2000
09	2400
0A	2800
0B	2C00
0C	3000
0D	3400
0E	3800
0F	3C00 — Maximum Number

Register 3 in the VDP contains the starting address for the Color Table.

(R3) * 40(16) STARTING ADDRESS

R3	START ADDRESS	R3	START ADDRESS	R3	START ADDRESS
00	0000	28	0A00	50	1400
01	0040	29	0A40	51	1440
02	0080	2A	0A80	52	1480
03	00C0	2B	0AC0	53	14C0
04	0100	2C	0B00	54	1500
05	0140	2D	0B40	55	1540
06	0180	2E	0B80	56	1580
07	01C0	2F	0BC0	57	15C0
08	0200	30	0C00	58	1600
09	0240	31	0C40	59	1640
0A	0280	32	0C80	5A	1680
0B	02C0	33	0CC0	5B	16C0
0C	0300	34	0D00	5C	1700
0D	0340	35	0D40	5D	1740
0E	0380	36	0D80	5E	1780
0F	03C0	37	0DC0	5F	17C0
10	0400	38	0E00	60	1800
11	0440	39	0E40	61	1840
12	0480	3A	0E80	62	1880
13	04C0	3B	0EC0	63	18C0
14	0500	3C	0F00	64	1900
15	0540	3D	0F40	65	1940
16	0580	3E	0F80	66	1980
17	05C0	3F	0FC0*	67	19C0
18	0600	40	1000	68	1A00
19	0640	41	1040	69	1A40
1A	0680	42	1080	6A	1A80
1B	06C0	43	10C0	6B	1AC0
1C	0700	44	1100	6C	1B00
1D	0740	45	1140	6D	1B40
1E	0780	46	1180	6E	1B80
1F	07C0	47	11C0	6F	1BC0
20	0800	48	1200	70	1C00
21	0840	49	1240	71	1C40
22	0880	4A	1280	72	1C80
23	08C0	4B	12C0	73	1CC0
24	0900	4C	1300	74	1D00
25	0940	4D	1340	75	1D40
26	0980	4E	1380	76	1D80
27	09C0	4F	13C0	77	1DC0

*Maximum number for 4K RAMs

WD9918/9928/9929

(R3) * 40(16) STARTING ADDRESS (Continued)

WD9918/9928/9929

R3	START ADDRESS	R3	START ADDRESS	R3	START ADDRESS
78	1E00	A6	2980	D3	34C0
79	1E40	A7	29C0	D4	3500
7A	1E80	A8	2A00	D5	3540
7B	1EC0	A9	2A40	D6	3580
7C	1F00	AA	2A80	D7	35C0
7D	1F40	AB	2AC0	D8	3600
7E	1F80	AC	2B00	D9	3640
7F	1FC0	AD	2B40	DA	3680
80	2000	AE	2B80	DB	36C0
81	2040	AF	2BC0	DC	3700
82	2080	B0	2C00	DD	3740
83	20C0	B1	2C40	DE	3780
84	2100	B2	2C80	DF	37C0
85	2140	B3	2CC0	E0	2800
86	2180	B4	2D00	E1	3840
87	21C0	B5	2D40	E2	3880
88	2200	B6	2D80	E3	38C0
89	2240	B7	2DC0	E4	3900
8A	2280	B8	2E00	E5	3940
8B	22C0	B9	2E40	E6	3980
8C	2300	BA	2E80	E7	39C0
8D	2340	BB	2EC0	E8	3A00
8E	2380	BC	2F00	E9	1A40
8F	23C0	BD	2F40	EA	3A80
90	2400	BE	2F80	EB	3AC0
91	2440	BF	2FC0	EC	3B00
92	2480	C0	3000	ED	3B40
93	24C0	C1	3040	EE	3B80
94	2500	C2	3080	EF	3BCD
95	2540	C3	30C0	F0	3C00
96	2580	C4	3100	F1	3C40
97	25C0	C5	3140	F2	3C80
98	2600	C6	3180	F3	3CC0
99	2640	C7	31C0	F4	2D00
9A	2680	C8	3200	F5	3D40
9B	26C0	C9	3240	F6	3D00
9C	2700	CA	3280	F7	3DC0
9D	2740	CB	32C0	F8	3E00
9E	2780	CC	3300	F9	3E40
9F	27C0	CD	3340	FA	3E80
A0	2800	CE	3380	FB	3EC0
A1	2840	CF	33C0	FC	3F00

(R3) * 40(16) STARTING ADDRESS (Concluded)

R3	START ADDRESS	R3	START ADDRESS	R3	START ADDRESS
A2	2880	D0	3400	FD	3F40
A3	28C0	D1	3440	FE	3F80
A4	2900	D2	3480	FF	3FC0
A5	2940				

Register 4 in the VDP contains the starting address for the Pattern Generator Sub-block.

(R4) * 800(16) = START ADDRESS

R4	START ADDRESS	
00	0000	
01	0800	— Max # for 4K RAMs
02	1000	
03	1800	
04	2000	
05	2800	
06	3000	
07	3800	— Max # for 16K RAMs

Register 5 in the VDP contains the starting address for the Sprite Attribute Table.

(R5) * 80(16) START ADDRESS

R5	START ADDRESS	R5	START ADDRESS	R5	START ADDRESS	R5	START ADDRESS
00	0000	21	1080	40	2000	60	3000
01	0080	22	1100	41	2080	61	3080
02	0400	23	1180	42	2100	62	3100
03	0180	24	1200	43	2180	63	3180
04	0200	25	1280	44	2200	64	3200
05	0280	26	1300	45	2280	65	3280
06	0300	27	1380	46	2300	66	3300
07	0380	28	1400	47	2380	67	3380
08	0400	29	1480	48	2400	68	3400
09	0480	2A	1500	49	2480	69	3480
0A	0500	2B	1580	4A	2500	6A	3500
0B	0580	2C	1600	4B	2580	6B	3580
0C	0600	2D	1680	4C	2600	6C	3600
0D	0680	2E	1700	4D	2680	6D	3680
0E	0700	2F	1780	4E	2700	6E	3700
0F	0780	30	1800	4F	2780	6F	3780
10	0800	31	1880	50	2800	70	3800
11	0880	32	1900	51	2880	71	3880

(R5) * 80(16) START ADDRESS

R5	START ADDRESS	R5	START ADDRESS	R5	START ADDRESS	R5	START ADDRESS
12	0900	33	1980	52	2900	72	3900
13	0980	34	1A00	53	2980	73	3980
14	0A00	35	1A80	54	2A00	74	3A00
15	0A80	36	1B00	55	2A80	75	3A80
16	0B00	37	1B80	56	2B00	76	3B00
17	0B80	38	1C00	57	2B80	77	3B80
18	0C00	39	1C80	58	2C00	78	3C00
19	0C80	3A	1D00	59	2C80	79	3C80
1A	0D00	3B	1D80	5A	2D00	7A	3D00
1B	0D80	3C	1E00	5B	2D80	7B	3D80
1C	0E00	3D	1E80	5C	2E00	7C	3E00
1D	0E80	3E	1F00	5D	2E80	7D	3E80
1E	0F00	3F	1F80	5E	2F00	7E	3F00
1F	0F80*			5F	2F80	7F	3F80
20	1000						

*Maximum number for 4K RAMs.

Register 6 contains the value for the starting address of the Sprite Pattern Generator sub-block.

$$\text{STARTING ADDRESS} = R6 * <800$$

R6	START ADDRESS	
00	0000	
01	0800	— Max # for 4K DRAMs
02	1000	
03	1800	
04	2000	
05	2800	
06	3000	
07	3800	— Max # for 16K RAMs

STATUS REGISTER

The VDP has a single 8-bit status register that can be accessed by the CPU. The status register contains the interrupt pending flag, the sprite coincidence flag, the fifth sprite flag, and the fifth sprite number, if one exists. The format of the status register is shown in Figure 22 and is discussed in the following paragraphs.

The status register may be read at any time to test the F, C, and 5S status bits. Reading the status register will clear the interrupt flag, F. However, asynchronous reads will cause the frame flag (F) bit to be reset and therefore missed. Consequently, the status register should be read only when the VDP interrupt is pending.

Interrupt Flag (F)

The F status flag in the status register is set to 1 at the end of the raster scan of the last line of the active display. It is reset to a 0 after the status register is read or when the VDP is externally reset. If the Interrupt Enable bit in VDP Register 1 is active (1), the VDP interrupt output (INT) will be active (low) whenever the F status flag is a 1.

Note that the status register needs to be read frame by frame in order to clear the interrupt the receive the new interrupt of the next frame.

Coincidence Flag (C)

The C status flag in the status register is set to a 1 if two or more sprites coincide. Coincidence occurs if any two sprites on the screen have one overlapping pixel. Transparent colored sprites, as well as those that are partially or completely off the screen, are also considered. Sprites beyond the Sprite Attribute Table terminator (D016) are not considered. The C flag is cleared to a 0 after the status register is read or the VDP is externally reset. The status register should be read immediately upon powerup to ensure that the coincidence flag is reset.

The VDP checks each pixel position for coincidence during the generation of the pixel regardless of where it is located on the screen. This occurs every 1/60th of a second for the WD9918 and WD9928 and every 1/50th of a second for the WD9929. Thus, when moving sprites more than one pixel position during these intervals, it is possible for the sprites to have multiple pixels overlapping or even to have passed completely over one another when the VDP checks for coincidence.

Fifth Sprite Flag (5S) and Number

The 5S status flag in the status register is set to a 1 whenever there are five or more sprites on a horizontal line (lines 0 to 192) and the frame flag is equal to a 0. The 5S status flag is cleared to a 0 after the status register is read or the VDP is externally reset. The number of the fifth sprite is placed into the lower 5 bits of the status register when the 5S flag is set and is valid whenever the 5S flag is 1. The setting of the fifth sprite flag will not cause an interrupt.

VDP/VRAM INTERFACE

The VDP can access up to 16,384 bytes of VRAM using a 14-bit VRAM address. The VDP fetches data from the VRAM in order to process the video image described later. The VDP also stores data in or reads in data from the VRAM during a CPU-VRAM data transfer. The VDP automatically refreshes the VRAM.

VRAM Interface Control Signals

The VDP-VRAM interface consists of two 8-bit data buses (RD0-RD7 unidirectional, AD0-AD7, bidirectional) and three control lines, as shown in Figure 23. The VRAM outputs data to the VDP on the VRAM read data bus (RD0-RD7). The VDP outputs both the address and data to the VRAM over the VRAM address/data bus (AD0-AD7). The VRAM row address is output when RAS is active (low). The column address is output when CAS is active (low). Data is output to the VRAM when RW is active (low).

VRAM Memory Types

The VDP can use 4K, 8K, or 16K dynamic RAMs. The 4/16K bit in VDP register 1 is a 0 for 4K RAMs and a 1 for 8K or 16K RAMs. There is a minor difference between the way 4K and 8K/16K RAMs are wired to the VDP. In the 4K, all CE pins are tied to ground. In the 8K/16K the A6 lines (the same pin as CE) are all tied to AD1 on the WD9918. A jumper can be used to select the VRAM type.

VDP to DRAM Address Connections

The VDP can be easily connected to either the 4K or 16K DRAMs. However, due to different pin numbering standards, it is possible to connect the VDP to the DRAMs incorrectly. Table 6 shows the recommended way to connect a VDP to either DRAM. Other DRAMs, such as the single +5V supply type, can also be used by following the 4K or 16K columns in Table 6.

Table 6.
VDP TO DRAM ADDRESS CONNECTIONS

VDP	16K DRAM	4K DRAM
AD0	Data Only	Data Only
AD1	A6	Data Only
AD2	A5	A5
AD3	A4	A4
AD4	A3	A3
AD5	A2	A2
AD6	A1	A1
AD7	A0	A0

When connecting the data ports together, ensure that corresponding RAMs (assuming 8 by 1 DRAMs) are properly connected to the corresponding input or output of the VDP. For example, AD0 of the corresponding input or output D input of the RAM, and RD0 of the VDP should connect to the Q output of the same RAM. The same is true for all AD and RD corresponding pins for each of the eight DRAMs.

NOTE:

CD0 is the MSB of the CD bus; CD7 is the LSB. AD0 is the MSB of the AD bus; AD7 is the LSB. RD0 is the MSB of the RD bus; RD7 is the LSB. RAMs have the reverse convention.

AD7 is the MSB of the AD bus, and AD0 is the LSB.

Therefore, AD7 of the VDP connects to AD, and AD1 connects to A6 of the 16K DRAM. Data coming into the VDP on CD0 goes to VRAM on AD0 and returns to the VDP on RD0.

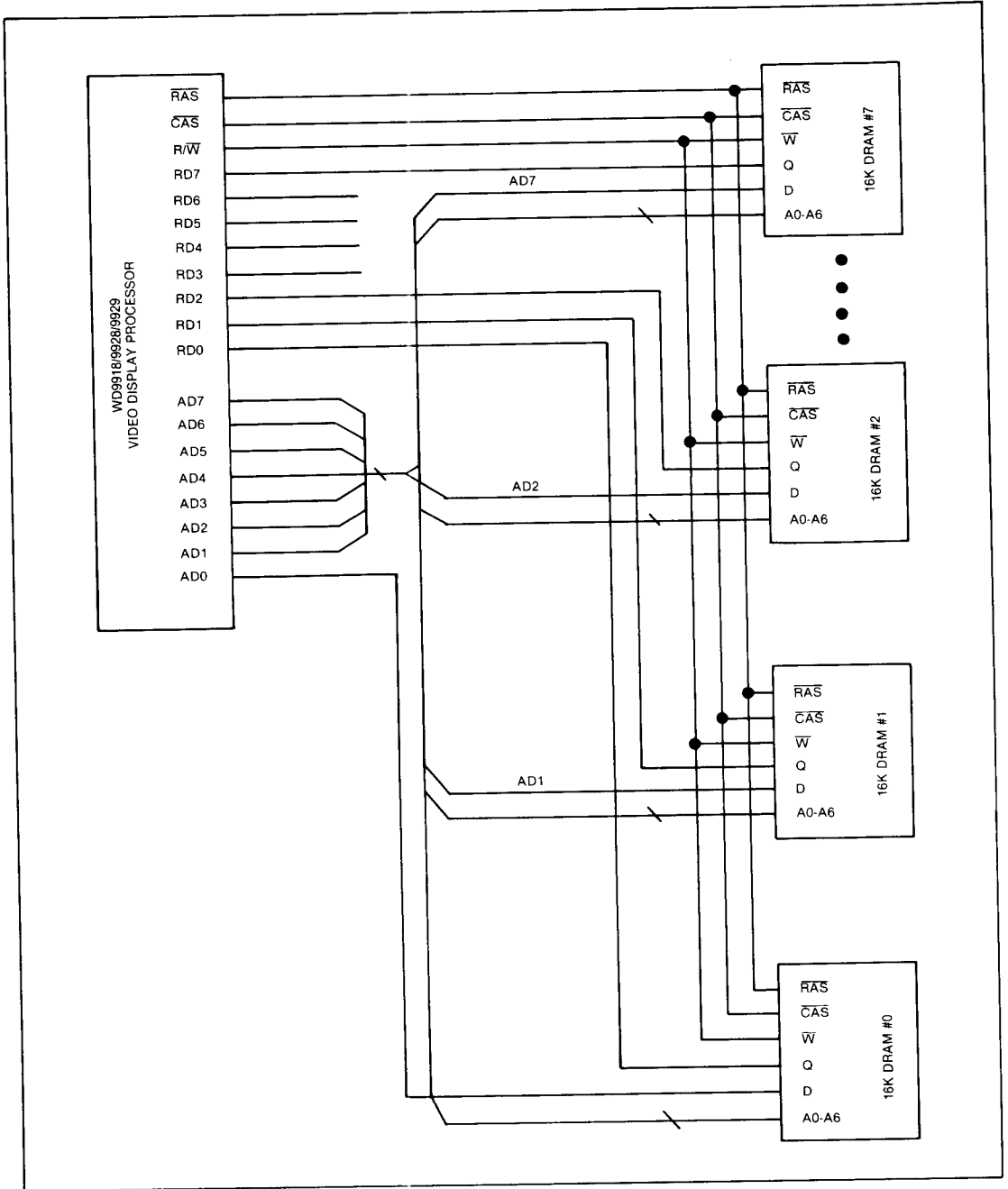

Figure 23. VRAM INTERFACE

VRAM MEMORY ADDRESS DERIVATION

Table 7 summarizes the VRAM address derivation for all VDP modes of operation.

Table 7. PATTERN GRAPHICS ADDRESS LOCATION TABLES

GRAPHICS I MODE ADDRESS LOCATION

ADDRESS TYPE	0	1	2	3	4	5	6	7	8	9	10	11	12	13	COMMENTS
1) Pattern Name Address	NTB			Row						Column				Pattern name table base (VDP REG2) Pattern position	
2) Pattern Color Address	COLB								0	Name (0-4)				Pattern color table base (VDP REG3) Always "0" in Bit 8 Five most significant bits of name	
3) Pattern Generator Address	PGB			Name							XXX			Pattern generator base (VDP REG4) All 8 bits of name Three LSB's form pattern row position	

GRAPHICS II MODE ADDRESS LOCATION

ADDRESS TYPE	0	1	2	3	4	5	6	7	8	9	10	11	12	13	COMMENTS
1) Pattern Name Address	NTB			Row						Column				Pattern name table base (VDP REG2) Pattern position row Pattern position column	
2) Pattern Color Address		XX		Name							XXX			Pattern color table base MSB (VDP REG3) Two MSB from vertical counter All 8 bits of name Color table byte/line	
3) Pattern Generator Address		XX		Name							XXX			Pattern name table base MSB (VDP REG4) Two MSB from vertical counter All 8 bits of name Pattern generator byte/line number	

TEXT MODE ADDRESS LOCATION

ADDRESS TYPE	0	1	2	3	4	5	6	7	8	9	10	11	12	13	COMMENTS
Text Mode Name Address	NTB			Text Position										Pattern name table base (VDP REG2) Equal (text position row # times 40) plus (text position column number)	
Text Mode Pattern Address	PGB			Name							XXX			Pattern generator base (VDP REG4) Name Byte/line number	

Table 7. PATTERN GRAPHICS ADDRESS LOCATION TABLES (CONTINUED)

SPRITE ADDRESS LOCATION

ADDRESS TYPE	0	1	2	3	4	5	6	7	8	9	10	11	12	13	COMMENTS
Sprite Attribute Address	SAB				Sprite							XX	Sprite attribute table base (VDP REG5) Sprite number Attribute number: 00 for vertical position 01 for horizontal position 10 for name 11 for TAG (early clock and color)		
Size = 0 Sprite Pattern Generator	SPGB		Name							XXX			Sprite pattern generator base (VDP REG4) Name attribute of Sprite Three LSB's give byte/line number		
Size = 1 Sprite Pattern Generator	SPGB		Name (0-5)					XXXXX			Sprite pattern generator base (VDP REG4) Six MSB of name Size = 1 Sprite byte number (See Figure 4-4)				

MULTICOLOR ADDRESS LOCATION

ADDRESS TYPE	0	1	2	3	4	5	6	7	8	9	10	11	12	13	COMMENTS
4) Multicolor Name Address	NTB			Row					Column			Name table base (VDP REG2) Pattern position row Pattern position column			
5) Multicolor Color Generator Address	PGB		Name							XXX			Pattern generator base (VDP REG4) Name from name fetch Three LSB's form byte/square row		

The WD9918/9928 operates at 262 lines per frame and approximately 60 frames per second in a noninterlaced mode of operation. The WD9929 operates at 313 lines per frame and approximately 50 frames per second in a noninterlaced mode of operation.

VRAM ADDRESSING EXAMPLE

A typical application might require up to 256 unique 8 x 8 patterns with no more than 2 colors per pattern and up to 32 8 x 8 sprites.

These conditions dictate in which mode the VDP is to be used. The sprite requirement and the 8 x 8 pattern blocks eliminate the text and multicolor modes, respectively. This leaves only the Graphics I and Graphics II modes, and since two colors per block are all that are necessary, Graphics I is employed due to its ease of use.

Figure 24 shows a memory map that allows these functions to fit into a 4K memory area.

Register values for Figure 24 are as follows:

- Register 0 = 00 External VDP disabled, M3 = 0
- Register 1 = C0 16K DRAM selected, Blank = 1, Graphics 1 mode selected, SIZE = 0, MAG = 0
- Register 2 = 01 Name Table Start Address @ >400
- Register 3 = 08 Color Table Start Address @ >0200
- Register 4 = 01 Pattern Generator Start Address @ >800
- Register 5 = 02 Sprite Attribute Table Start Address >100
- Register 6 = 00 Sprite Pattern Generator Start Address @ >0000
- Register 7 = XX Determined by user.

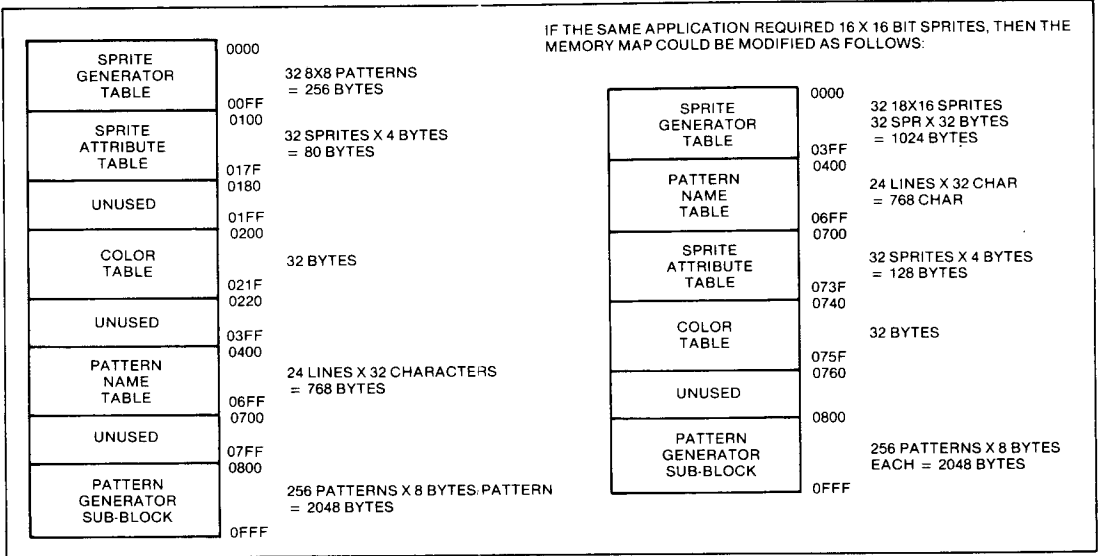

Figure 24. VDP-VRAM MEMORY ALLOCATION

MONITOR INTERFACES

WD9918 Monitor Interface

The composite video output signal from the WD9918 drives a color monitor. This signal incorporates all necessary horizontal and vertical synchronization signals as well as luminance and chrominance information. In monitor applications, the requirements of the monitor should be studied to determine if the VDP can be connected directly to it. The internal output buffer device on the composite video pin is a source-follower MOS transistor that requires an external pull-down resistor to VSS as shown in Figure 25. Typically a 330-ohm resistor is recommended to provide a 1.9-

volt synchronization level. The load resistor (RL) defines the sharpness of the edges on the video signals. A lower resistor value gives faster fall times and a sharper picture.

In some cases, it may be necessary to provide a simple interface circuit to match the VDP output voltages with the monitor specifications. To drive a standard television that is not outfitted with a composite video input, the signal can be run into the television antenna terminals by using an appropriate RF modulator of the VDP output. Take care to ensure a proper match between VDP, RF modulator, and TV.

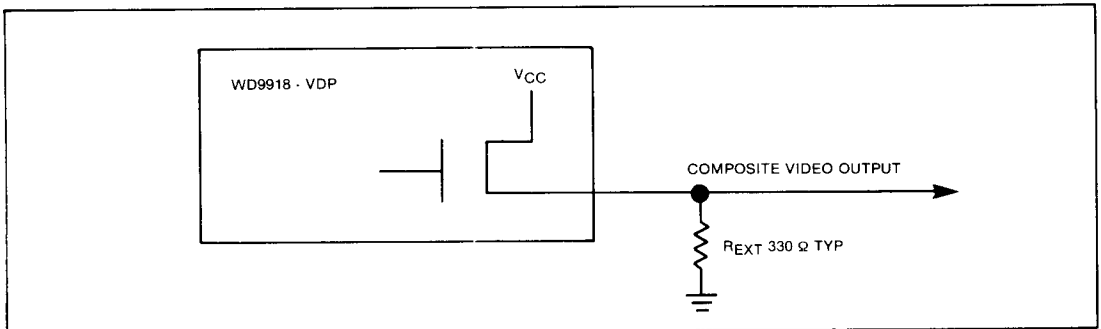

Figure 25. COMPOSITE VIDEO PULL-DOWN CIRCUIT

WD9928/9929 Monitor Interface

The Y, R-Y and B-Y output signals require external encoder circuitry to drive a video color monitor; an R-G-B matrix circuitry is required to drive R-G-B color monitors. The Y output signal contains all necessary horizontal and vertical synchronization signals as well as luminance while the R-Y and B-Y signals con-

tain the unmodulated chrominance information and are used in the NTSC and PAL systems to modulate two carriers in quadrature. The internal output buffer devices on these pins are source-follower MOS transistors that require an external pull-down resistor to VSS, as shown in Figure 26. A 330 ohm resistor is recommended.

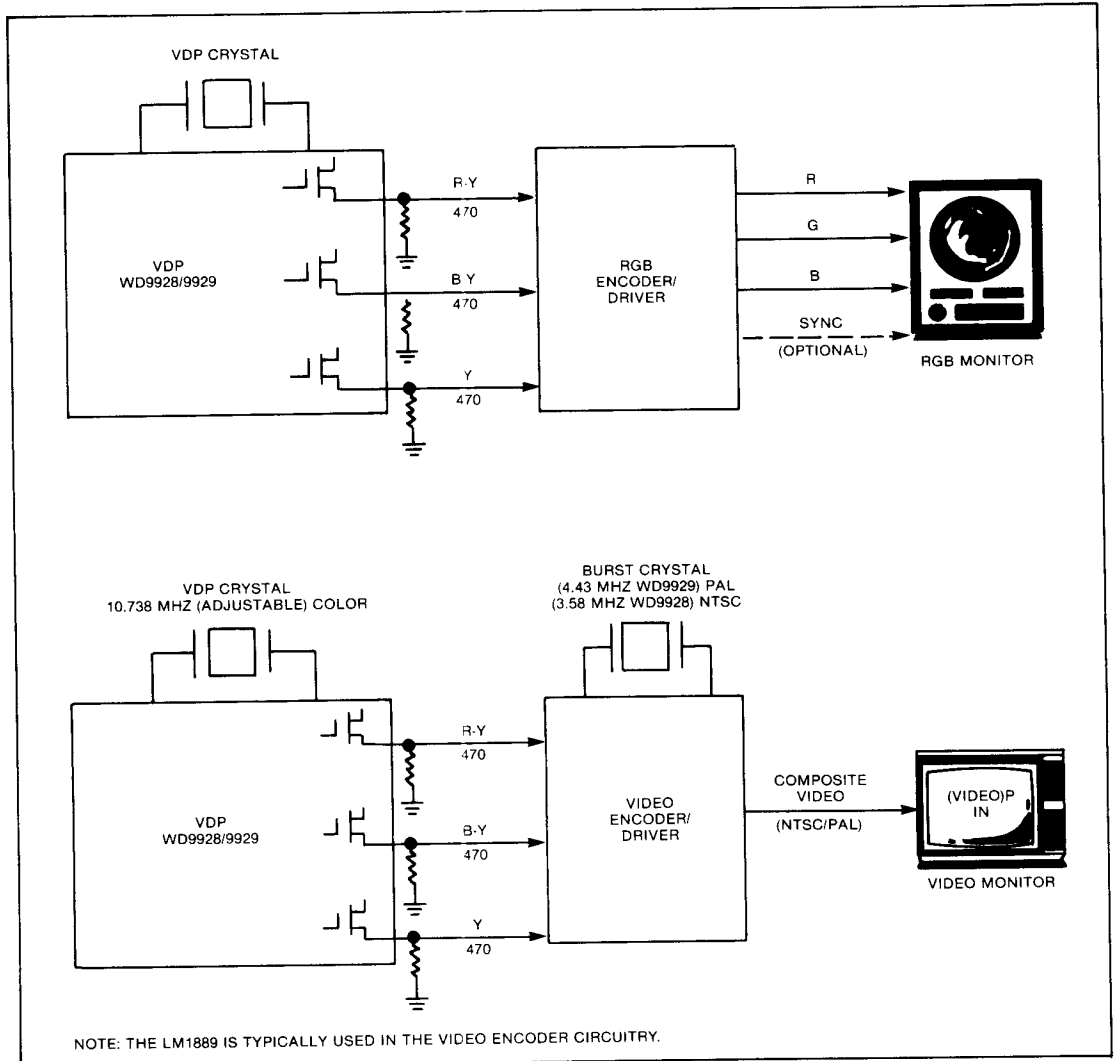

Figure 26. USE OF WD9928/9929 WITH DIFFERENT MONITORS

WD9918 EXTERNAL VDP OPERATION

The external VDP interface allows cascading multiple VDPs. Figures 27 and 28 illustrate cascading two VDPs. Note that the VDPs must be reset by a common reset source to assure synchronization on an open loop basis. This reset source should have fast edges so that rise and fall times are less than 30 ns. Occasionally, synchronization is not obtained after reset, in which case, reset should be reapplied.

The video matching circuit ensures that the video signal of external VDP is biased correctly and of the

proper amplitude. This ensures the luminance levels of the external and VDP colors are matched and external VDP video does not bleed through into the composite video output of the first VDP. The internal circuit assures that a perfect match results if the external video is of the same amplitude as the composite video of the VDP and its dc level is increased by a MOS threshold voltage (typically 0.7 volts). This adjustment can be varied to change the relative luminance levels of the two video signals and thus modify the picture appearance.

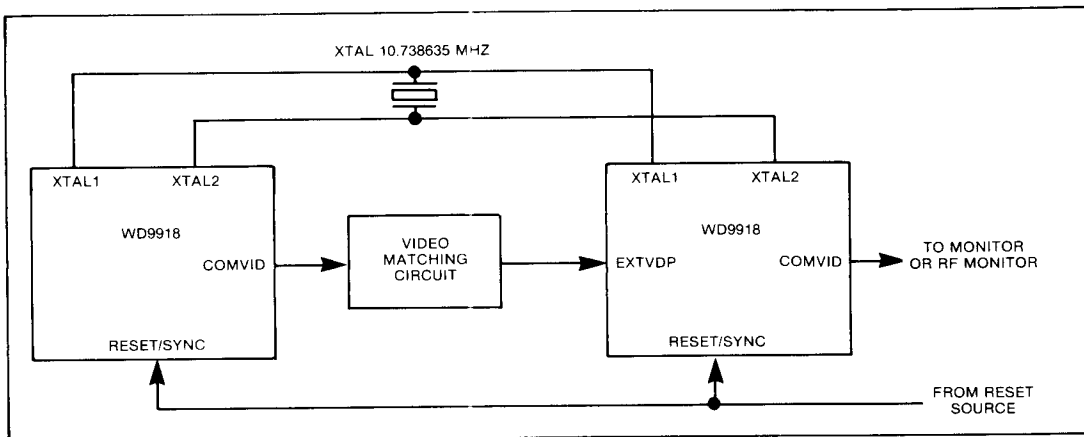

Figure 27. CASCADING TWO WD9918 VDPs

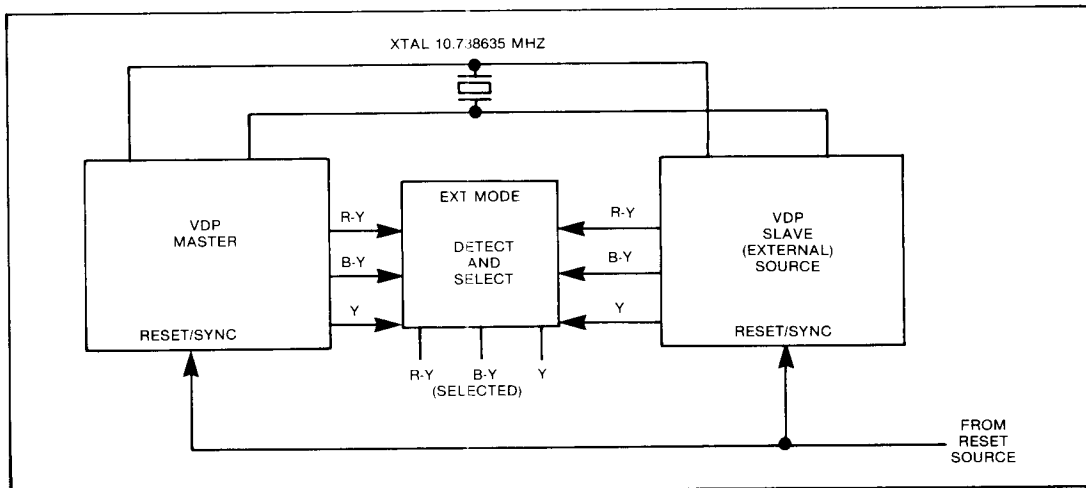

Figure 28. CASCADING TWO WD9918/9929 VDPs

For the External VDP input plane to be visible, the External VDP Enable bit in VDP Register 0 (EXVID) should be set to a 1. The backdrop color (VDP Register 7, lower 4 bits) should be set to transparent (0). For the external VDP plane to show through at a given spot on the screen, the pattern color at that spot should be transparent, and all sprites should not be in the way (alternatively, a sprite that was in the way could be made transparent in color). Note that the external VDP feature can be used in either Graphics I, Graphics II, Text, or Multicolor mode.

OSCILLATOR AND CLOCK GENERATION

The VDP is designed to operate with a 10.738635 ± 0.005 MHz crystal input to generate the required internal clock-signals. A fundamental-frequency parallel-mode crystal is the frequency reference for the internal clock oscillator, which is the master time base for all system operations. This master clock is divided by two to generate the pixel clock (5.3 MHz) and by three to provide the CPUCLK (3.58 MHz for WD9918 only). The GROMCLK is developed from the master clock frequency divided by 24 (3.58 MHz for WD9928 only).

WD9918 Color Phase Generation

The 10.7 + MHz master clock and its complement generate an internal six-phase 3.579545 MHz ± 10 Hz

clock to provide the video color signals and the color burst reference used in developing the composite video output signal. While the VDP signals are not exact equivalents to the standard NTSC colors, the differences can easily be adjusted with the color and tint controls of the target color monitor.

Video Sync and Control Generation

Decoding the outputs of the horizontal and vertical counters generates the horizontal and vertical control signals. The pixel clock drives the horizontal counter which in turn increments the vertical counter.

Table 8 gives the relative count values of the screen display parameters. Within the active display area during Graphics I mode, the three LSBs of the horizontal counter address the individual picture element of each pattern displayed. Also, during the vertical active display period, the three LSBs of the vertical counter address each individual line in the 8 x 8 patterns. The Graphics II, Multicolor and Text modes use the counters similarly.

The WD9918/9929 operates at 262 lines per frame and approximately 60 frames per second in a noninterlaced mode of operation. The WD9929 operates at 313 lines per frame and approximately 50 frames per second in a noninterlaced mode of operation.

Table 8. SCREEN DISPLAY PARAMETERS

PARAMETER	PIXEL CLOCK CYCLES	
	PATTERN OR MULTICOLOR	TEXT
HORIZONTAL		
Horizontal Active Display	256	240
Right Border	15	25
Right Blanking	8	8
Horizontal SYNC	26	26
Left Blanking	2	2
Color Burst	14	14
Left Blanking	8	8
Left Border	13	19
	342	342
VERTICAL	LINE	
Vertical Active Display	192	
Bottom Border	24	
Bottom Blanking	3	
Vertical SYNC	3	
Top Blanking	13	
Top Border	27	
	262	

WD9918/9928/9929 Crystals

Crystals for the WD9918/9928/9929 can be purchased from the following:

NDK
 10080 North Wolfe Rd., Suite 220
 Cupertino, CA 95014
 Telephone: (408) 255-0831
 Telex: 352057

CTS Knights, Inc.
 400 Reiman Ave.
 Sandwich, Ill. 60548
 Telephone: (815) 786-8411

Supply voltage, V_{CC} - 0.3 to 20V
 All input voltages - 0.3 to 20V
 Output voltage - 2 to 7V
 Continuous power dissipation 1.3 W
 Operating free-air temperature range 0°C to 70°C
 Storage temperature range - 55°C to + 150°C

*Stresses beyond those listed under Absolute Maximum Ratings may cause permanent damage to the device. This is a stress rating only and functional operation of the device at these or any other conditions beyond those indicated in the Recommended Operating Conditions section of this specification is not implied. Exposure to absolute maximum rated conditions for extended periods may affect device reliability.

WD9918/9928/9929 ELECTRICAL SPECIFICATIONS

ABSOLUTE MAXIMUM RATINGS OVER OPERATING FREE-AIR TEMPERATURE RANGE (unless otherwise noted)*

RECOMMENDED OPERATING CONDITIONS*

PARAMETER	MIN	NOM	MAX	UNIT
Supply voltage, V _{CC}	4.75		5.25	V
Supply voltage, V _{SS}		0		V
Input Voltage V _I , RESET/SYNC pin				
SYNC active	10		12	V
RESET active			0.6	V
SYNC and RESET inactive	3		6	V
High-level input, V _{IH}				
XTAL1, XTAL2	2.75			V
All other inputs	2.2			V
Input voltage, V _I , EXT VDP pin (WD9918 only)				
SYNC level		2.6		V
White level		3.7		V
Black level		3		V
Low-level input voltage, V _{IL}			0.8	V
Operating free-air temperature, T _A	0		70	°C

*All voltage values are with respect to V_{SS}.

ELECTRICAL CHARACTERISTICS OVER FULL RANGES OF RECOMMENDED OPERATING CONDITIONS
(unless otherwise noted)

WD9918/9928/9929

SYMBOL	PARAMETER	TEST CONDITIONS	MIN	TYP†	MAX	UNIT
VOH	High-level RAS, CAS, R/W Output voltage	IOH = 400 μA	2.7	3.4		V
	All other outputs	IOH = 400 μA	2.4	3.2		V
VOL	Low-level CPU data Output voltage	IOL = 1.2 mA		0.3	0.6	V
	DRAM interface	IOL = 800 μA			0.6	V
IOZH	Off-state output current high-level voltage applied, D0-D7 outputs	VO = 5.25 V		1	100	μA
IOZL	Off-state output current high-level voltage applied, D0-D7 outputs	VO = 0.4 V		1	-100	μA
IiH	High-level input current	VI = 5.25 V, all other pins at 0 V			10	μA
IiL	Low-level input current	VI = 0 V, all other pins at 0 V			-10	μA

WD9918 Only (Figure 29)

SYMBOL	PARAMETER	TEST CONDITIONS	MIN	NOM	MAX	UNIT
Vwhite	Video voltage level of white, COMVID	RL = 470 Ω	2.8	3.0	3.2 V	
Vblack	Video voltage level of black (blank), COMVID	RL = 470 Ω	2.1	2.3	2.5 V	
Vsync	Video voltage level of sync, COMVID	RL = 470 Ω	1.85	2.0	2.1 V	

† All typical values are at VCC = 5.25 V, TA = 25°C.

ELECTRICAL CHARACTERISTICS OVER FULL RANGES OF RECOMMENDED OPERATING CONDITIONS
(unless otherwise noted) (Continued)

WD9928/9929 Only (Figure 29)

SYMBOL	PARAMETER	TEST CONDITIONS	MIN	NOM	MAX	UNIT
Vwhite	Video voltage level of white, Y, R-Y, B-Y outputs	RL = 470 Ω	2.5	3	3.6	V
Vblack	Video voltage level of black (blank), Y, R-Y, B-Y outputs	RL = 470 Ω	1.6	2.3	2.5	V
Vsync	Video voltage level of sync, Y output	RL = 470 Ω	1.2	1.8	2	V

WD9929 Only

SYMBOL	PARAMETER	TEST CONDITIONS	MIN	TYP	MAX	UNIT
VPS	Color burst video voltage level with respect to V no color	R-Y output		0.25		V
Vneg	Color burst video voltage level with respect to V no color	B-Y output		-0.25		V

WD9918/9928/9929 (Figure 30)

SYMBOL	PARAMETER	TEST CONDITIONS	MIN	NOM	MAX	UNIT
	Video voltage difference, white-black, Y, R-Y, B-Y outputs		0.7	1.0		V
I _{CC}	Average supply current from V _{CC}	T _A = 25°C		200	250	mA
C _i	Input capacitance D0-D7 All other inputs	unmeasured f = 11 MHz, pins at 0 V			20 10 10	pF
C _o	Output capacitance	unmeasured f = 11 MHz, pins at 0 V			20	pF

† All typical values are at V_{CC} = 5.25 V, T_A = 25°C.

TIMING REQUIREMENTS OVER FULL RANGES OF RECOMMENDED OPERATING CONDITIONS (WD9918/9928/9929)

CPU - VDP Interface (Figures 31 and 32)

SYMBOL	PARAMETER	MIN	NOM	MAX	UNIT
t _{su} (A-RL)	Address setup time before CSR low		0		ns
t _{su} (A-WL)	Address setup time before CSW low		30		ns
t _h (WL-A)	Address hold time after CSW low		30		ns
t _{su} (D-WH)	Data setup time before CSW high		100		ns
t _h (WH-D)	Data hold time after CSW high		30		ns
t _w (WL)	Pulse width, CSW low		200		ns
t _w (CS-H1)	Pulse width, chip select high (requesting memory access)		8		μs
t _w (CS-H2)	Pulse width, chip select high (not requesting memory access)		2		μs

VDP - VRAM Interface (Figures 33 and 34)

SYMBOL	PARAMETER	MIN	NOM	MAX	UNIT
t _c	Memory read or write cycle time	372			ns
t _{su} (D-CH)	Input data setup time before CAS high	60			ns
t _h (CH-D)	Input data hold time after CAS high	0			ns

External Clock Source (Figure 35)

SYMBOL	PARAMETER	MIN	NOM	MAX	UNIT
f _{ext}	External source frequency	10.738098	10.738635	10.739172	MHz
t _r /t _f	External source rise/fall time		10	15	ns
t _{wH}	External source high-level pulse width	42	47	52	ns
t _{wL}	External source low-level pulse width	42	47	52	ns
t _{pD}	External source phase delay from XTAL1 falling edge to XTAL2 falling edge	42	47	52	ns

SWITCHING CHARACTERISTICS OVER FULL RANGE OF RECOMMENDED OPERATING CONDITIONS
(WD9918/9928/9929)

CPU - VDP Interface

SYMBOL	PARAMETER	TEST CONDITIONS	MIN	TYP†	MAX	UNIT
tA(CSR)	Data access time from CSR low	C _L = 300 pF		100	150	ns
tpVX	Data disable time after CSR high	C _L = 300 pF		65	100	ns
tpVX,A	Data invalid time from address changes	C _L = 300 pF		0		ns
fCPUCLK	CPU clock output clock frequency (fext + 3)	C _I = 300 pF	3.4	3.58	3.76	MHz
fGROMCLK	GROM clock output clock frequency (fext + 24)	C _L = 300 pF	425.12	447.5	469.88	kHz

VDP - VRAM Interface (Figures 33 and 34)

SYMBOL	PARAMETER	TEST CONDITIONS	MIN	TYP	MAX	UNIT
t _w	Pulse width, \overline{CAS} high	C _L = 50 pF	80	100	120	ns
t _w (CL)	Pulse width, \overline{CAS} low	C _L = 50 pF	220	230	250	ns
t _w (RH)	Pulse width, \overline{RAS} high	C _L = 50 pF	100	125	150	ns
t _w (RL)	Pulse width, \overline{RAS} low	C _L = 50 pF	190	210	230	ns
t _w (W)	Pulse width, write pulse	C _L = 50 pF	170	190	210	ns
t _{CA-CL}	Delay time, column address to \overline{CAS} low	C _L = 50 pF	- 10	- 2		ns
t _{RA-RL}	Delay time, row address to \overline{RAS} low	C _L = 50 pF	25	45	65	ns
t _{d-WL}	Delay time, data to \overline{RW} low	C _L = 50 pF	0	6	20	ns
t _{WH-CL}	Delay time, \overline{RW} high to \overline{CAS} low	C _L = 50 pF	25	50	75	ns
t _{W-CH}	Delay time, \overline{RW} low to \overline{CAS} high	C _L = 50 pF	120	140	160	ns
t _{W-RH}	Delay time, \overline{RW} low to \overline{RAS} high	C _L = 50 pF	60	75	90	ns

SWITCHING CHARACTERISTICS OVER FULL RANGE OF RECOMMENDED OPERATING CONDITIONS
(WD9918/9928/9929) (Continued)

WD9918 Composite video output (Figures 36 and 37)

SYMBOL	PARAMETER	TEST CONDITIONS	MIN	TYP	MAX	UNIT
t _{CL-CA}	Column address valid after \overline{CAS} low	C _L = 50 pF	45	65	85	ns
t _{RL-RA}	Row address valid after \overline{RAS} low	C _L = 50 pF	20	25	30	ns
t _{RL-CA}	Column address valid after \overline{RAS} low	C _L = 50 pF	95	110	130	ns
t _{CL-D}	Data valid after \overline{CAS} low	C _L = 50 pF	240	260	280	ns
t _{RL-D}	Data valid after \overline{RAS} low	C _L = 50 pF	95	110	125	ns
t _{WL-D}	Data valid after \overline{RW} low	C _L = 50 pF	135	165	195	ns
t _{CH-WL}	Read command valid after \overline{CAS} high	C _L = 50 pF	0			ns
t _{CL-W}	Write command valid after \overline{CAS} low	C _L = 50 pF	270	290	310	ns
t _{CH-RL}	Delay time, \overline{CAS} high to \overline{RAS} low	C _L = 50 pF	45	65		ns
t _{CL-RH}	Delay time, \overline{CAS} low to \overline{RAS} high	C _L = 50 pF	150	170	190	ns
t _{RL-CL}	Delay time, \overline{RAS} low to \overline{CAS} low	C _L = 50 pF	30	40	50	ns
t _{fl}	Fall time, V _{black} to V _{sync}			10		ns
t _w (HS)	Pulse width, horizontal sync			4.84		μs
t _{rl}	Rise time, V _{sync} to V _{black}			20		ns
t _{HS-CD}	Delay time, sync to color burst			372		ns

WD9918 Composite video output (Figures 36 and 37) (CONTINUED)

SYMBOL	PARAMETER	TEST CONDITIONS	MIN	TYP	MAX	UNIT
t _w (CB)	Width, color burst			261		μs
t _{CB-LB}	Delay time, color burst to left border			1.49		μs
t _{r2}	Rise time, V _{black} to V _{white}	R _L = 470 Ω		60		ns
t _w (LB)	Left border video width	C _L = 150 pF		2.42		μs
t _{f2}	Fall time, V _{white} to V _{black}			110		ns
t _w (AD)	Width of active display area			47.68		μs
t _w (RB)	Right border video width			2.79		μs
t _{RB-HS}	Delay time, right border to horizontal sync			1.49		μs
t _{vFB}	Vertical front blanking			191.1		μs
t _{vS}	Vertical sync			191.1		μs
V _{VBB}	Vertical back blanking			828		μs
t _{ABA}	Active plus border area time			18.8		ms

NOTE: Fall times depend on external pull-down resistor.

SWITCHING CHARACTERISTICS OVER FULL RANGE OF RECOMMENDED OPERATING CONDITIONS (WD9918/9928/9929) (Continued)

WD9928/9929 Y, R-Y, B-Y outputs (Figures 38 through 41)

SYMBOL	PARAMETER	TEST CONDITIONS	MIN	TYP	MAX	UNIT
t _{f3}	Fall time, V _{black} to V _{sync}			100		ns
t _w (HSI)	Pulse width, horizontal sync			4.84		μs
t _{r3}	Rise time, V _{sync} to V _{black}			150		ns
t _w (BP)	Width, back porch			4.47		μs
t _w (LBI)	Width, left border			2.8		μs
t _w (P)	Pulse width, pixel			186.24		ns
t _w (horz)	Width, horizontal line			63.695		μs
t _w (ADI)	Width, active display area			47.67		μs
t _{r4}	Rise time, V _{black} to V _{white}			75		ns
t _{f4}	Fall time, V _{white} to V _{black}			50		ns
t _w (RBI)	Width, right border			2.42		μs
t _w (FP)	Width, front porch	R _L = 470 Ω		1.49		μs
t _{r5}	Rise time, V no color to V pos CB	C _L = 15 pF		150		ns
t _w (CB1)	Pulse width, pos color burst			2.6		μs
t _{f5}	Fall time, V pos CB to V no color			100		ns
t _w (CB-LBI)	Delay time, pos CB to left border			1.49		μs
t _{f6}	Fall time, V no color to V neg CB			100		ns
t _{r6}	Rise time, V neg CB to V no color			150		ns
t _w (VSI)	Pulse width, vertical sync			465		ns
t _{vFBI}	Vertical front blanking			191.09		μs
t _{vSI}	Vertical sync			191.09		μs
t _{vBBI}	Vertical back blanking			828.04		μs
t _{ABA1}	Active area plus border area total			18.70		ms
	Vertical time			19.91		ms

NOTE: Fall times depend on external pull-down resistor.

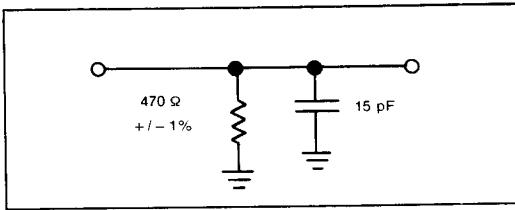

Figure 29.
LOAD CIRCUIT FOR COMVID (ALL DEVICES)
AND R-Y, Y, B-Y SWITCHING CHARACTERISTICS
(WD9928/9929)

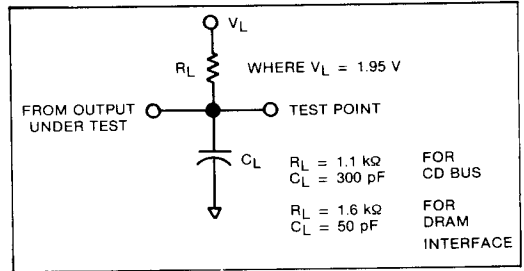

Figure 30. LOAD CIRCUITS FOR ALL OUTPUTS
EXCEPT COMVID, R-Y, Y, B-Y

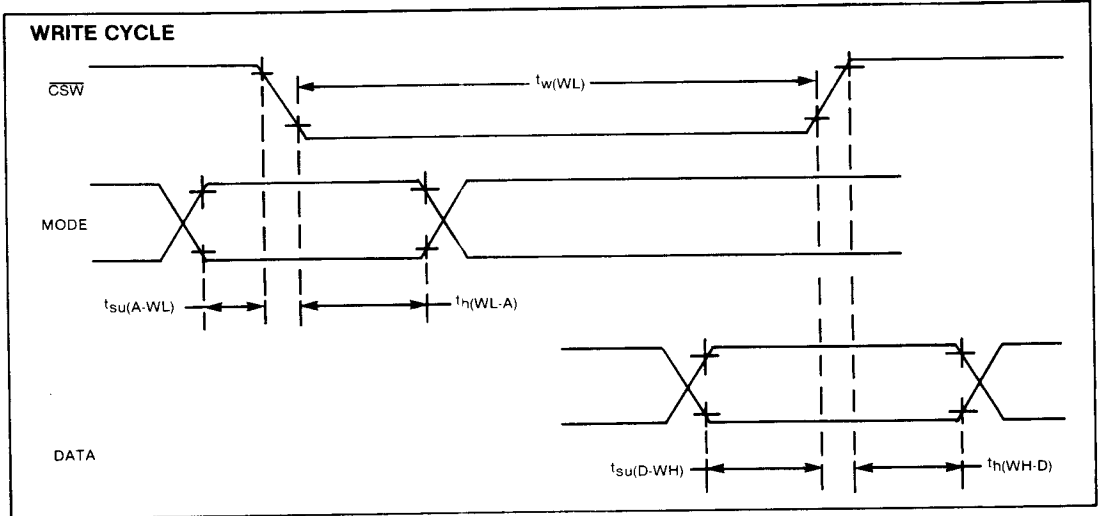

Figure 31. CPU - VDP WRITE CYCLE FOR WD9918/9928/9929

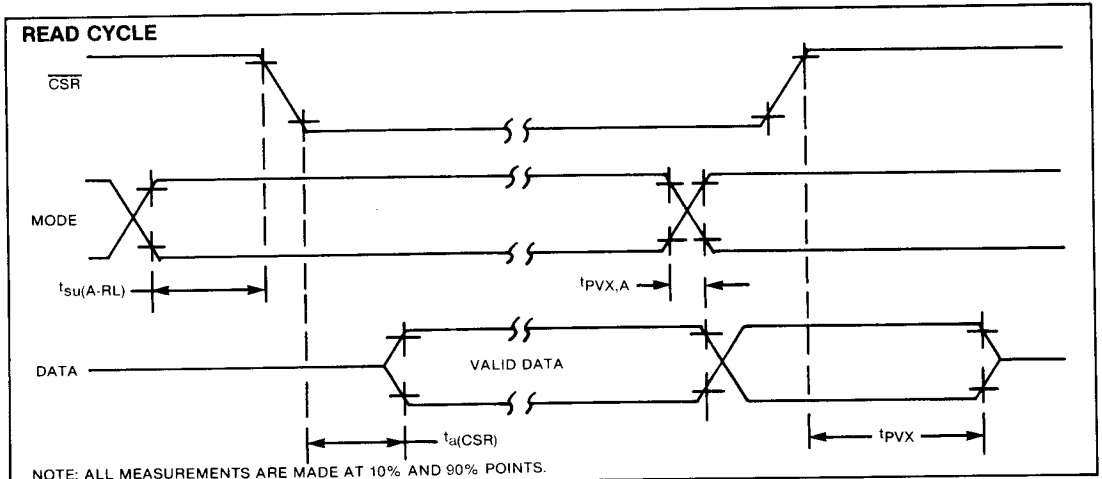

Figure 32. CPU - VDP READ CYCLE FOR WD9918/9928/9929

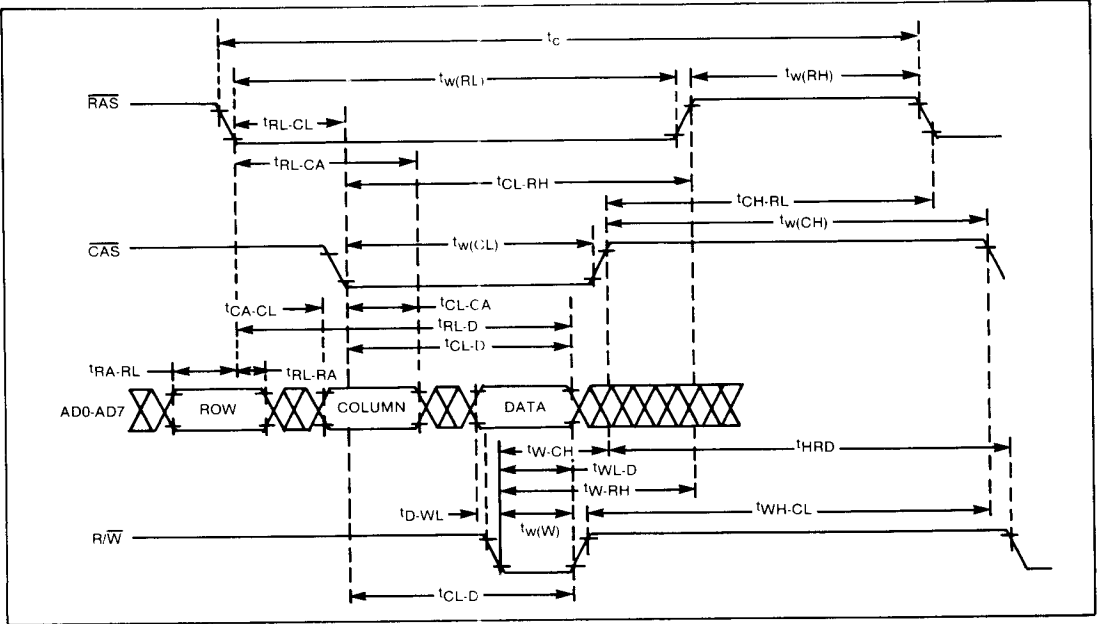
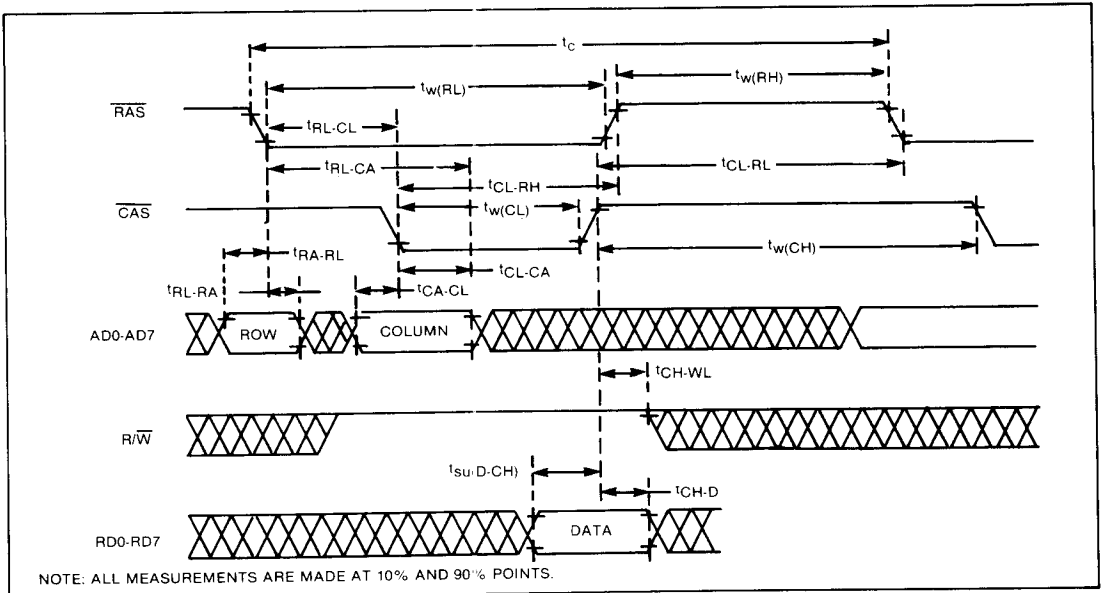

Figure 33. VRAM WRITE CYCLE



NOTE: ALL MEASUREMENTS ARE MADE AT 10% AND 90% POINTS.

Figure 34. VRAM READ CYCLE

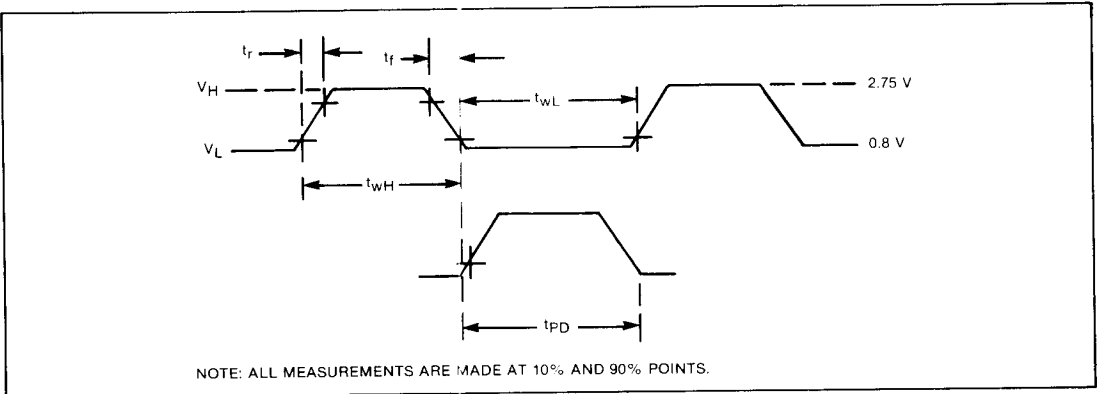

Figure 35. EXTERNAL CLOCK TIMING WAVEFORM

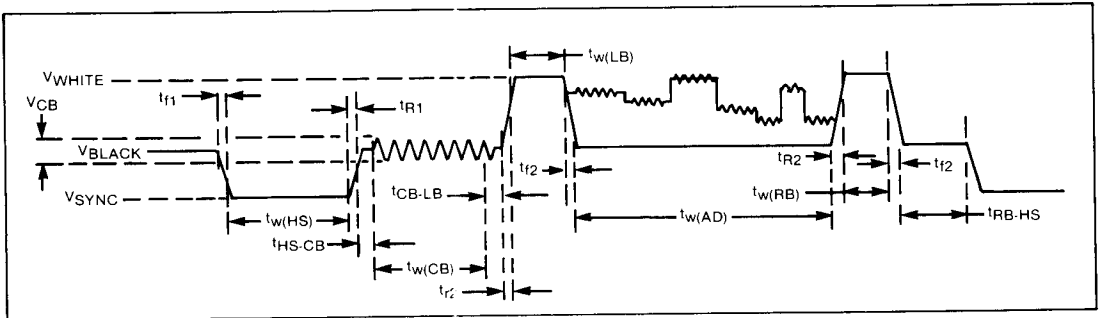

Figure 36. WD9918 COMVID HORIZONTAL TIMING

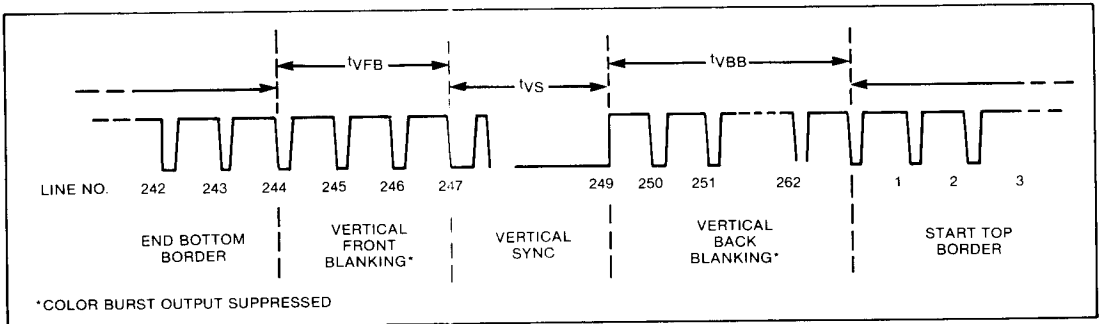

Figure 37. WD9918 VERTICAL TIMING

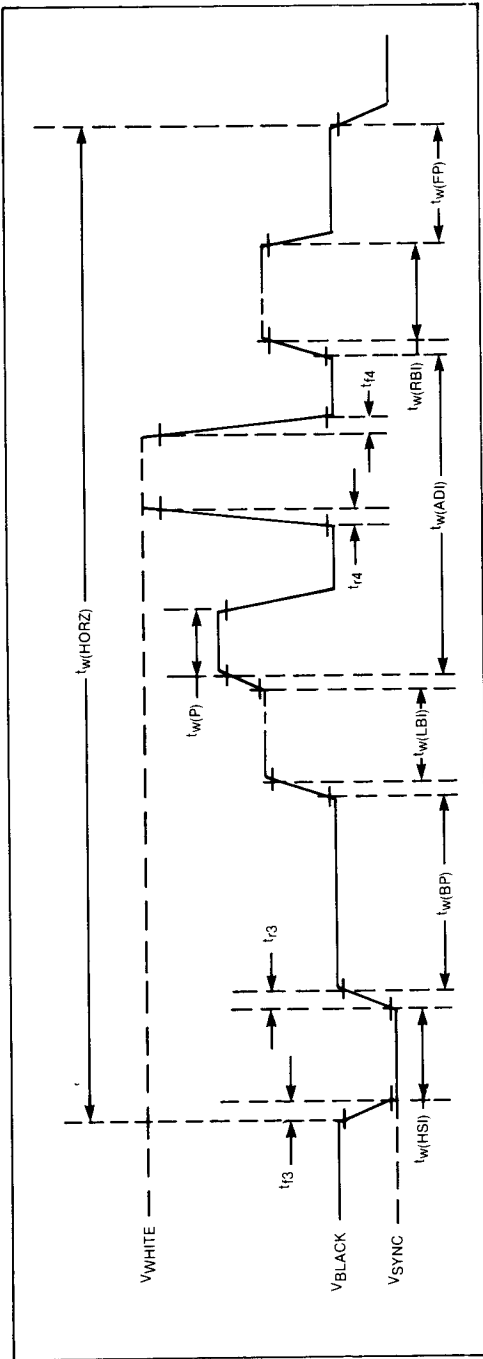

Figure 38. WD9928/9929 Y HORIZONTAL TIMING

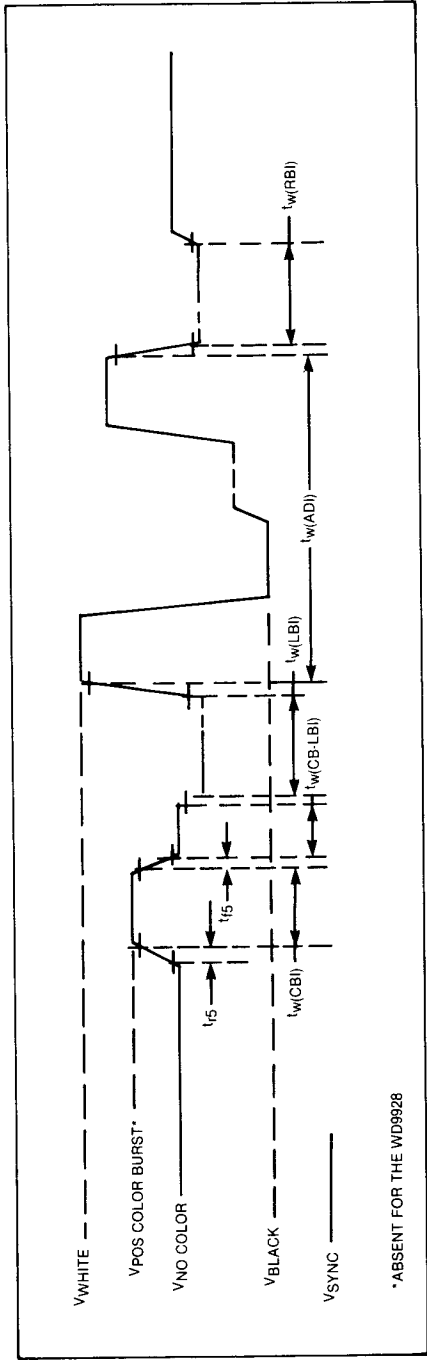

Figure 39. WD9928/9929 R-Y HORIZONTAL TIMING

*ABSENT FOR THE WD9928

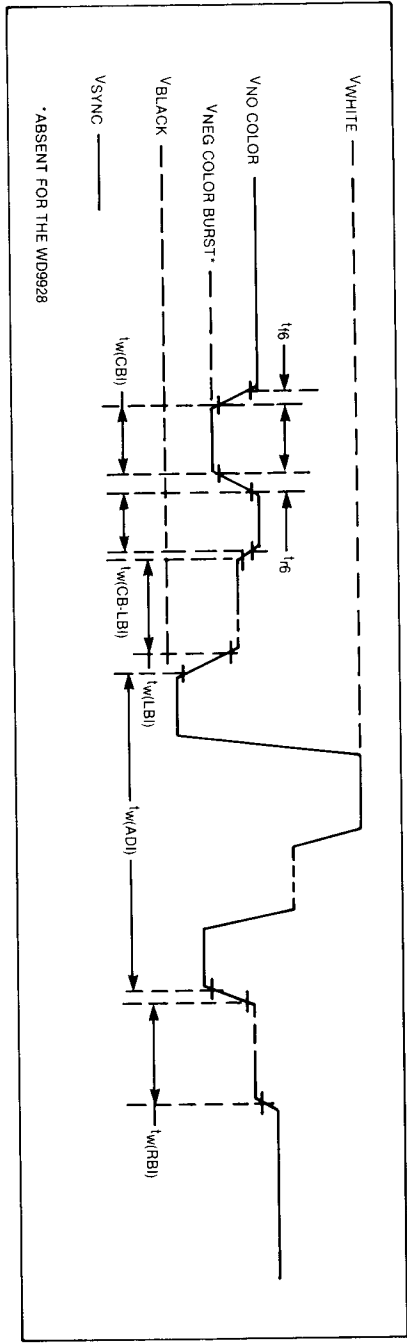

Figure 40. WD9928/9929 B-Y HORIZONTAL TIMING

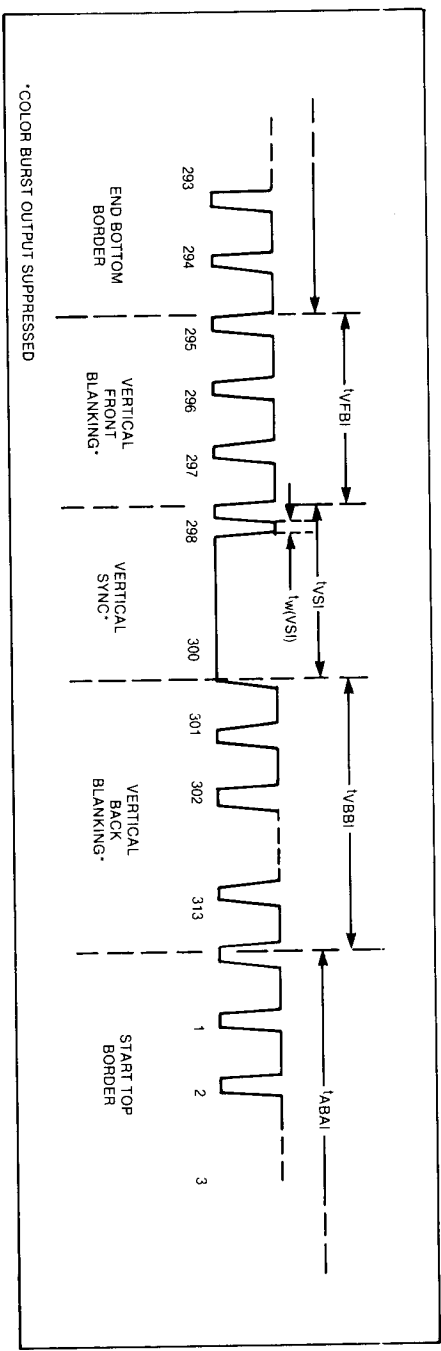

Figure 41. WD9929 VERTICAL TIMING

WD9918/9928/9929